

ASME B16.42-2021
(Revision of ASME B16.42-2016)

Ductile Iron Pipe Flanges and Flanged Fittings

Classes 150 and 300

AN AMERICAN NATIONAL STANDARD



**The American Society of
Mechanical Engineers**

ASME B16.42-2021
(Revision of ASME B16.42-2016)

Ductile Iron Pipe Flanges and Flanged Fittings

Classes 150 and 300

AN AMERICAN NATIONAL STANDARD



**The American Society of
Mechanical Engineers**

Two Park Avenue • New York, NY • 10016 USA

Date of Issuance: February 4, 2022

The next edition of this Standard is scheduled for publication in 2026.

ASME issues written replies to inquiries concerning interpretations of technical aspects of this Standard. Periodically certain actions of the ASME B16 Committee may be published as Cases. Cases and interpretations are published on the ASME website under the Committee Pages at <http://cstools.asme.org/> as they are issued.

Errata to codes and standards may be posted on the ASME website under the Committee Pages to provide corrections to incorrectly published items, or to correct typographical or grammatical errors in codes and standards. Such errata shall be used on the date posted.

The Committee Pages can be found at <http://cstools.asme.org/>. There is an option available to automatically receive an e-mail notification when errata are posted to a particular code or standard. This option can be found on the appropriate Committee Page after selecting “Errata” in the “Publication Information” section.

ASME is the registered trademark of The American Society of Mechanical Engineers.

This code or standard was developed under procedures accredited as meeting the criteria for American National Standards. The Standards Committee that approved the code or standard was balanced to assure that individuals from competent and concerned interests have had an opportunity to participate. The proposed code or standard was made available for public review and comment that provides an opportunity for additional public input from industry, academia, regulatory agencies, and the public-at-large.

ASME does not “approve,” “rate,” or “endorse” any item, construction, proprietary device, or activity.

ASME does not take any position with respect to the validity of any patent rights asserted in connection with any items mentioned in this document, and does not undertake to insure anyone utilizing a standard against liability for infringement of any applicable letters patent, nor assume any such liability. Users of a code or standard are expressly advised that determination of the validity of any such patent rights, and the risk of infringement of such rights, is entirely their own responsibility.

Participation by federal agency representative(s) or person(s) affiliated with industry is not to be interpreted as government or industry endorsement of this code or standard.

ASME accepts responsibility for only those interpretations of this document issued in accordance with the established ASME procedures and policies, which precludes the issuance of interpretations by individuals.

No part of this document may be reproduced in any form,
in an electronic retrieval system or otherwise,
without the prior written permission of the publisher.

The American Society of Mechanical Engineers
Two Park Avenue, New York, NY 10016-5990

Copyright © 2022 by
THE AMERICAN SOCIETY OF MECHANICAL ENGINEERS
All rights reserved

CONTENTS

Foreword	v
Committee Roster	vi
Correspondence With the B16 Committee	vii
Summary of Changes	ix
List of Changes in Record Number Order	x
1 Scope	1
2 General	1
3 Pressure–Temperature Ratings	2
4 Size	2
5 Marking	3
6 Materials	3
7 Dimensions	3
8 Tolerances	5
9 Testing	5
Mandatory Appendix	
I References	22
Nonmandatory Appendices	
A Quality System Program	23
B Methods for Establishing Pressure–Temperature Ratings	24
Figures	
4.2-1 Method of Designating Outlets of Reducing Fittings	7
7.9.3-1 Method of Designating Location of Tapped Holes for Drains When Specified	21
Tables	
3.1-1 Pressure–Temperature Ratings	6
3.1-1C Pressure–Temperature Ratings	6
7.1.1-1 Dimensions of Class 150 Elbows, Double Branch Elbows, Tees, Crosses, Laterals, True Ys (Straight Sizes), and Reducers	8
7.1.1-2 Dimensions of Class 300 Elbows, Tees, Crosses, Laterals, True Ys (Straight Sizes), and Reducers	10
7.1.4-1 Dimensions of Class 150 Base Elbows and Base Tees	12
7.1.4-2 Dimensions of Class 300 Base Elbows and Base Tees	13
7.3-1 Templates for Drilling Class 150 Ductile Iron Flanges	14
7.3-2 Templates for Drilling Class 300 Ductile Iron Flanges	15

7.4-1	Dimensions of Class 150 Ductile Iron Flanges	16
7.4-2	Dimensions of Class 300 Ductile Iron Flanges	18
7.5.2-1	Reducing Threaded Flanges for Classes 150 and 300	20

FOREWORD

In 1921, the American Engineering Standards Committee, later the American Standards Association (ASA), now the American National Standards Institute (ANSI), authorized the organization of a Sectional Committee on the Standardization of Pipe Flanges and Flanged Fittings, with the following organizations as joint sponsors: Heating, Piping, and Air Conditioning Contractors National Association [later the Mechanical Contractors Association of America (MCAA)], Manufacturers Standardization Society of the Valves and Fittings Industry (MSS), and The American Society of Mechanical Engineers (ASME). Cast iron flanges and flanged fittings are within the scope of Subcommittee No. 1 (now Subcommittee A), with standards approved by ASA as early as 1928.

In 1957, piping components of ductile iron (also called nodular iron and, in Europe, spheroidal graphite iron) first appeared on the market. Controversy immediately developed over proper pressure–temperature ratings, and this was further aggravated by the use of casting patterns for both gray iron and carbon steel for producing the components.

Conflicting philosophies, which emerged from that controversy, thwarted efforts by MSS to develop standard practices in the early 1960s; the conflicts persisted during a study of ratings, starting in 1966 by American National Standards Committee B16 (as the Sectional Committee was called after reorganization of ASA as ANSI). The conflict continued to delay acceptance and approval of this Standard, which ultimately originated with a draft developed by MSS (taking advantage of earlier efforts) and submitted to Subcommittee A in 1977. Combining that draft with the rating basis developed in the B16 Committee, the first edition of this Standard was found acceptable and was approved by the Standards Committee, cosecretariat organizations, and ANSI, and was published with the designation ANSI B16.42-1979.

In 1982, American National Standards Committee B16 was reorganized as an ASME Committee operating under procedures accredited by ANSI. The 1987 edition of the Standard updated the referenced standards and specifications, and established U.S. Customary units as the standard. Following approval by the Standards Committee and ASME, ANSI granted its approval of the edition as an American National Standard on July 13, 1987, with the new designation ASME/ANSI B16.42-1987.

In the 1998 edition of ASME B16.42, reference standards were updated, a quality system program annex was added, and several editorial revisions were made. Following approval by ASME B16 Subcommittee B and the B16 Standards Committee, ANSI approved the American National Standard on November 20, 1998.

Metric units were provided as an independent but parallel alternative standard to the U.S. Customary units in the 2011 edition. Following approval by the Standards Committee and the ASME Board on PTCS, the revision to the 1998 edition of this Standard was approved as an American National Standard by ANSI on August 9, 2011, with the new designation ASME B16.42-2011.

In the 2016 edition, revisions were made to table and appendix references. Following approval by the ASME B16 Standards Committee, ANSI approved ASME B16.42-2016 on November 7, 2016.

In ASME B16.42-2021, the U.S. Customary tables in former Mandatory Appendix I have been merged with the SI tables in the main text. The tables and figures have been redesignated, former Mandatory Appendix I has been deleted, and the subsequent Mandatory Appendix has been redesignated. Cross-references have been updated accordingly. Also in this edition, [Table 3.1-1](#) (formerly Table 1), [Table 3.1-1C](#) (formerly Table I-1), [Table 7.1.1-1](#) (formerly Tables 3 and I-3), [Table 7.1.1-2](#) (formerly Tables 4 and I-4), [para. 3.1](#), and [sections 5](#) and [6](#) have been revised, and the references in [Mandatory Appendix I](#) (formerly Mandatory Appendix II) have been updated. Following approval by the ASME B16 Standards Committee, ASME B16.42-2021 was approved by ANSI on December 10, 2021.

ASME B16 COMMITTEE

Standardization of Valves, Flanges, Fittings, and Gaskets

(The following is the roster of the Committee at the time of approval of this Standard.)

STANDARDS COMMITTEE OFFICERS

C. E. Davila, *Chair*
R. M. Bojarczuk, *Vice Chair*
S. J. Rossi, *Secretary*

STANDARDS COMMITTEE PERSONNEL

A. Appleton , Alloy Stainless Products Co., Inc.	T. A. McMahon , Emerson Automation Solutions
J. E. Barker , DeZURIK, Inc.	R. C. Merrick , Consultant
R. W. Barnes , ANRIC Enterprises, Inc.	W. H. Patrick , Dow Chemical Co.
D. C. Bayreuther , Neles Corp.	D. W. Raho , CCM 2000
W. B. Bedesem , Consultant	D. F. Reid , VSP Technologies
R. M. Bojarczuk , Retired	S. J. Rossi , The American Society of Mechanical Engineers
A. M. Cheta , Shell Global Solutions (U.S.)	R. A. Schmidt , Canadoil
M. A. Clark , NIBCO, Inc.	J. Sekerak , CSA Group
G. A. Cuccio , Capitol Manufacturing Co.	F. R. Volstadt , Volstadt and Associates, Inc.
C. E. Davila , Crane Chempharma and Energy	F. Feng , <i>Delegate</i> , China Productivity Center for Machinery
K. S. Felder , Valero Energy	J. D. Grant , <i>Alternate</i> , DeZURIK, Inc.
D. R. Frikken , Becht Engineering Co., Inc.	P. V. Craig , <i>Contributing Member</i> , Jomar Group
J. R. Holstrom , Val-Matic Valve and Manufacturing Corp.	B. G. Fabian , <i>Contributing Member</i> , Pennsylvania Machine Works
D. Hunt, Jr. , Fastenal	A. G. Kireta, Jr. , <i>Contributing Member</i> , Copper Development Association, Inc.
G. A. Jolly , Samshin Ltd.	
E. J. Lain , Exelon Nuclear	

SUBCOMMITTEE B — THREADED FITTINGS (EXCEPT STEEL), FLANGES, AND FLANGED FITTINGS

D. Hunt, Jr. , <i>Chair</i> , Fastenal	M. C. Coffey , Ward Manufacturing, LLC
J. R. Holstrom , <i>Vice Chair</i> , Val-Matic Valve and Manufacturing Corp.	R. Kelsey , NIBCO, Inc.
R. R. Rahaman , <i>Secretary</i> , The American Society of Mechanical Engineers	W. LeVan , Cast Iron Soil Pipe Institute
J. Atkinson , Consultant	G. L. Simmons , Charlotte Pipe and Foundry
W. Bliss , Tyler Pipe Co.	G. T. Walden , Ferguson
M. A. Clark , NIBCO, Inc.	C. A. Mueller , <i>Alternate</i> , Mueller Streamline Co.

CORRESPONDENCE WITH THE B16 COMMITTEE

General. ASME Standards are developed and maintained with the intent to represent the consensus of concerned interests. As such, users of this Standard may interact with the Committee by requesting interpretations, proposing revisions or a case, and attending Committee meetings. Correspondence should be addressed to:

Secretary, B16 Standards Committee
The American Society of Mechanical Engineers
Two Park Avenue
New York, NY 10016-5990
<http://go.asme.org/Inquiry>

Proposing Revisions. Revisions are made periodically to the Standard to incorporate changes that appear necessary or desirable, as demonstrated by the experience gained from the application of the Standard. Approved revisions will be published periodically.

The Committee welcomes proposals for revisions to this Standard. Such proposals should be as specific as possible, citing the paragraph number(s), the proposed wording, and a detailed description of the reasons for the proposal, including any pertinent documentation.

Proposing a Case. Cases may be issued to provide alternative rules when justified, to permit early implementation of an approved revision when the need is urgent, or to provide rules not covered by existing provisions. Cases are effective immediately upon ASME approval and shall be posted on the ASME Committee web page.

Requests for Cases shall provide a Statement of Need and Background Information. The request should identify the Standard and the paragraph, figure, or table number(s), and be written as a Question and Reply in the same format as existing Cases. Requests for Cases should also indicate the applicable edition(s) of the Standard to which the proposed Case applies.

Interpretations. Upon request, the B16 Standards Committee will render an interpretation of any requirement of the Standard. Interpretations can only be rendered in response to a written request sent to the Secretary of the B16 Standards Committee.

Requests for interpretation should preferably be submitted through the online Interpretation Submittal Form. The form is accessible at <http://go.asme.org/InterpretationRequest>. Upon submittal of the form, the Inquirer will receive an automatic e-mail confirming receipt.

If the Inquirer is unable to use the online form, he/she may e-mail the request to the Secretary of the B16 Standards Committee at SecretaryB16@asme.org, or mail it to the above address. The request for an interpretation should be clear and unambiguous. It is further recommended that the Inquirer submit his/her request in the following format:

Subject:	Cite the applicable paragraph number(s) and the topic of the inquiry in one or two words.
Edition:	Cite the applicable edition of the Standard for which the interpretation is being requested.
Question:	Phrase the question as a request for an interpretation of a specific requirement suitable for general understanding and use, not as a request for an approval of a proprietary design or situation. Please provide a condensed and precise question, composed in such a way that a “yes” or “no” reply is acceptable.
Proposed Reply(ies):	Provide a proposed reply(ies) in the form of “Yes” or “No,” with explanation as needed. If entering replies to more than one question, please number the questions and replies.
Background Information:	Provide the Committee with any background information that will assist the Committee in understanding the inquiry. The Inquirer may also include any plans or drawings that are necessary to explain the question; however, they should not contain proprietary names or information.

Requests that are not in the format described above may be rewritten in the appropriate format by the Committee prior to being answered, which may inadvertently change the intent of the original request.

Moreover, ASME does not act as a consultant for specific engineering problems or for the general application or understanding of the Standard requirements. If, based on the inquiry information submitted, it is the opinion of the Committee that the Inquirer should seek assistance, the inquiry will be returned with the recommendation that such assistance be obtained.

ASME procedures provide for reconsideration of any interpretation when or if additional information that might affect an interpretation is available. Further, persons aggrieved by an interpretation may appeal to the cognizant ASME Committee or Subcommittee. ASME does not “approve,” “certify,” “rate,” or “endorse” any item, construction, proprietary device, or activity.

Attending Committee Meetings. The B16 Standards Committee regularly holds meetings and/or telephone conferences that are open to the public. Persons wishing to attend any meeting and/or telephone conference should contact the Secretary of the B16 Standards Committee.

ASME B16.42-2021

SUMMARY OF CHANGES

Following approval by the ASME B16 Standards Committee and ASME, and after public review, ASME B16.42-2021 was approved by the American National Standards Institute on December 10, 2021.

In ASME B16.42-2021, the U.S. Customary tables in former Mandatory Appendix I have been merged with the SI tables in the main text. The tables and figures have been redesignated, former Mandatory Appendix I has been deleted, and the subsequent Mandatory Appendix has been redesignated. Cross-references have been updated accordingly. In addition, this edition includes the following changes identified by a margin note, **(21)**. The Record Numbers listed below are explained in more detail in the “List of Changes in Record Number Order” following this Summary of Changes.

<i>Page</i>	<i>Location</i>	<i>Change (Record Number)</i>
2	3.1	Revised (19-922)
3	5	Subparagraph (b) revised (19-922)
3	6.1	Revised (19-922)
6	Table 3.1-1	Seventh row and Note (1) added (19-922)
6	Table 3.1-1C	Note (1) added (19-922)
8	Table 7.1.1-1	(1) 45-deg Lateral, Reducer, Eccentric Reducer, and True Y illustrations revised (19-920) (2) Face-to-Face Lateral column added, and subsequent three column heads revised (19-920)
10	Table 7.1.1-2	(1) 45-deg Lateral, Reducer, Eccentric Reducer, and True Y illustrations revised (19-920) (2) Face-to-Face Lateral column added, and subsequent three column heads revised (19-920)
22	Mandatory Appendix I	Former Mandatory Appendix II updated (21-621)

LIST OF CHANGES IN RECORD NUMBER ORDER

<u>Record Number</u>	<u>Change</u>
19-920	Added face-to-face lateral dimensions to Table 7.1.1-1 (former Tables 3 and I-3) and Table 7.1.1-2 (former Tables 4 and I-4).
19-922	Added ductile iron, ASTM A536 Grade 65-45-12 material.
21-621	Updated references in Mandatory Appendix I (former Mandatory Appendix II).

DUCTILE IRON PIPE FLANGES AND FLANGED FITTINGS

Classes 150 and 300

1 SCOPE

This Standard covers minimum requirements for Classes 150 and 300 cast ductile iron pipe flanges and flanged fittings. The requirements covered are as follows:

- (a) pressure–temperature ratings
- (b) sizes and method of designating openings of reducing fittings
- (c) marking
- (d) material
- (e) dimensions and tolerances
- (f) bolts, nuts, and gaskets
- (g) tests

2 GENERAL

2.1 References

Standards and specifications adopted by reference in this Standard are shown in [Mandatory Appendix I](#), which is part of this Standard. It is not considered practical to identify in the text the specific edition of each referenced standard and specification. Instead, the specific editions are identified in [Mandatory Appendix I](#).

2.2 Quality Systems

Requirements relating to the product manufacturers' quality system programs are described in [Nonmandatory Appendix A](#).

2.3 Relevant Units

This Standard states values in both SI (metric) and U.S. Customary units. As an exception, diameters of bolts and flange bolt holes are only expressed in inch units. These systems of units are to be regarded separately as standard. In this Standard, the U.S. Customary units are shown in parentheses or in separate tables following the SI tables. The values stated in each system are not exact equivalents; therefore, it is required that each system of units be used independently of the other. Except for the diameters of bolts and flange bolt holes, combining values from the two systems constitutes nonconformance with the Standard.

2.4 Service

Criteria for selection of materials suitable for particular fluid service are not within the scope of this Standard.

2.5 Convention

For determining conformance with this Standard, the convention for fixing significant digits where limits (maximum and minimum values) are specified shall be as defined in ASTM E29. This requires that an observed or calculated value be rounded off to the nearest unit in the last right-hand digit used for expressing the limit. Decimal values and tolerances do not imply a particular method of measurement.

2.6 Denotation

2.6.1 Pressure Rating Designation. Class, followed by a dimensionless number, is the designation for pressure–temperature ratings, as follows:

- (a) Class 150
- (b) Class 300

2.6.2 Size. NPS, followed by a dimensionless number, is the designation for nominal flange or flanged fitting size. NPS is related to the referenced nominal diameter, DN, used in metric units. The relationship is typically as follows:

NPS	DN
1	25
1¼	32
1½	40
2	50
2½	65
3	80
3½	90
4	100

For $NPS \geq 4$, the related $DN = 25 \times NPS$.

3 PRESSURE-TEMPERATURE RATINGS

(21) 3.1 General

Cast ductile iron pipe flanges and flanged fittings covered by this Standard shall be designated Class 150 or Class 300.

Except as provided in [para. 3.5](#), ratings are maximum allowable working pressures, expressed as gage pressure, at the service temperature from -29°C (-20°F) minimum to 343°C (650°F) maximum for ASTM A395 or 260°C (500°F) maximum for ASTM A536 Grade 65-45-12 (see [Tables 3.1-1](#) and [3.1-1C](#)). These minimum and maximum temperatures may be further limited by referencing regulations, codes, or specifications. For intermediate temperatures, linear interpolation is permitted. The method used for establishing pressure-temperature ratings is shown in [Nonmandatory Appendix B](#).

3.2 Ratings of Flanged Joints

Ratings in this Standard apply to flanged joints that conform to the limitations on bolting in [para. 6.2](#) and on gaskets in [para. 7.8](#), and which are made up in accordance with good practice for alignment and assembly (see also [para. 3.4](#)).

Use of the ratings for flanged joints not conforming to these limitations is the sole responsibility of the user. A flanged joint is composed of separate and independent, although interrelated, components: the flanges, the gasket, and the bolting, which are assembled by another influence, the assembler. Proper controls must be exercised in the selection and application for all these elements to attain a joint that has acceptable leak tightness. Special techniques, such as controlled bolt tightening, are described in ASME PCC-1.

If the two flanges in a flanged joint do not have the same pressure-temperature ratings, the rating of the joint at any temperature is the lower of the two flange ratings at that temperature.

3.3 Rating Temperature

Temperatures shown for corresponding pressure rating shall be the material temperature of the pressure-retaining structure. It may be assumed that the material temperature is the same as the fluid temperature. Use of a pressure rating at a material temperature other than that of the contained fluid is the responsibility of the user and subject to the requirements of any applicable code or regulation.

3.4 Temperature Considerations

Application of the ratings in this Standard to flanged joints at both high and low temperatures shall take into consideration the risk of leakage due to forces and moments developed in the connected piping or equip-

ment. The provisions in [paras. 3.4.1](#) and [3.4.2](#) are intended to minimize these risks.

3.4.1 Flange Attachment. Threaded flanges are not recommended for service above 260°C (500°F) if severe thermal gradients or thermal cycling is involved.

3.4.2 High-Temperature Service. When used above 205°C (400°F), Class 150 flanged joints may develop leakage unless care is taken to avoid imposing severe external loads and/or severe thermal gradients.

3.5 Variances From Ratings

Except as provided herein, ratings are the maximum allowable working pressure for the corresponding temperature.

3.5.1 Safety or Relief Valve Operation. Under conditions of safety valve, relief valve, or rupture disk operation, the pressure on a flange or flanged fitting may exceed the rated pressure at the pressure-relieving temperature by no more than 10%. Such conditions are necessarily of short duration. Overpressure greater than the aforementioned under pressure-relieving conditions is the responsibility of the user, subject to the requirements of the applicable code or regulation.

3.5.2 Other Variances. Operating variations (transients) that subject a flange or flanged fitting to pressure in excess of the rated pressure at the corresponding temperature are the responsibility of the user, subject to the requirements of the applicable code or regulation.

3.5.3 System Hydrostatic Test. Flanged joints and flanged fittings may be subjected to system hydrostatic tests at a pressure not to exceed the hydrostatic shell test pressure specified in [para. 9.3](#). Testing at any higher pressure is the responsibility of the user.

4 SIZE

4.1 Nominal Size

As applied in this Standard, the use of the phrase “nominal pipe size” or the designation NPS followed by a dimensionless number is for identifying the end connection of piping, flanges, or flanged fittings. The number is not necessarily the same as the inside diameter of the flange or flanged fitting. The diameter of a bolt is its nominal size. Use of nominal indicates that the stated size or dimension is only for designation, not measurement.

4.2 Reducing Fitting Sizes

Reducing fittings shall be designated by the size of the openings in their proper sequence as indicated in the sketches (see [Figure 4.2-1](#)).

4.3 Reducing Flange Sizes

Reducing flanges shall be designated by the two nominal pipe sizes. See examples in [Table 7.5.2-1](#), Note (4).

(21) 5 MARKING

Except as modified herein, flanges and flanged fittings shall be marked as required in MSS SP-25.

(a) *Name.* The manufacturer's name or trademark shall be applied.

(b) *Material.* The word "DUCTILE," or "DI" where space does not permit "DUCTILE," and the ASTM designation of either "A395" or "A536" shall be applied.

(c) *Rating Class.* Numerals shall be applied giving the pressure rating class for which the product is designed.

(d) *Designation.* The designation "B16" shall be applied, preferably located adjacent to the Class designation, to indicate conformance to this Standard.

(e) *Temperature.* No temperature markings are required on flanges and flanged fittings, but if marked, the temperature shall be shown with its corresponding tabulated pressure rating.

(f) *Size.* The nominal pipe size shall be applied, but may be omitted from reducing flanges and reducing flanged fittings.

6 MATERIALS

(21) 6.1 Castings

Ductile iron castings covered by this Standard shall conform to ASTM A395 or ASTM A536 Grade 65-45-12. The castings shall not be repaired by plugging, welding, brazing, or impregnation.

6.2 Bolting

Bolting listed in [paras. 6.2.1](#) and [6.2.2](#) is recommended to be used in flanged joints covered by this Standard. Bolting of other material may be used if permitted by the applicable code or governmental regulation.

6.2.1 High-Strength Bolting. Bolting materials having allowable stresses not less than those for ASTM A193/A193M Grade B7 may be used with any flanged joint at all listed temperatures. The strength of the nut shall be not less than that specified for ASTM A194/A194M Grade 2H.

6.2.2 Low-Strength Bolting. Bolting materials with yield strength equivalent to ASTM A307 Grade B are considered low strength, and may be used for flanged joints at temperatures not greater than 205°C (400°F) and only with gaskets described in [para. 7.8](#).

6.2.3 Bolting to Cast Iron Flanges. When Class 150 ductile iron flanges are bolted to Class 125 cast iron flanges, or Class 300 ductile iron flanges are bolted to Class 250 cast iron flanges, it is recommended that

low-strength boltings be used within the limitations in [para. 6.2.2](#). If high-strength bolting is used, it is recommended that the mating flanges be flat faced and that full-faced gaskets (ASME B16.5, Table B-1, Gasket Group Number 1a) extending to the O.D. of the flange be used.

6.3 Gaskets

Materials listed in ASME B16.5, Table B-1 shall be used. The user is responsible for selection of gasket materials that will withstand the expected bolt load without injurious crushing and that are suitable for the service conditions.

For low-strength bolting described in [para. 6.2.2](#), only gaskets listed in Group 1a (ASME B16.5, Table B-1) shall be used.

7 DIMENSIONS

7.1 Center to Contact Surface and Center to End

7.1.1 Standard Fittings. Center-to-contact-surface dimensions are shown in [Tables 7.1.1-1](#) and [7.1.1-2](#).

7.1.2 Reducing Fittings. Center-to-contact-surface or center-to-flange-edge dimensions for all openings shall be the same as those of straight size fittings of the largest opening. The contact-surface-to-contact-surface dimensions for all combinations of reducers and eccentric reducers shall be as listed for the larger opening.

7.1.3 Side-Outlet Fittings. Side-outlet elbows, side-outlet tees, and side-outlet crosses shall have all openings on intersecting centerlines, and the center-to-contact-surface dimensions of the side outlet shall be the same as for the largest opening. Long-radius elbows with side outlet shall have the side outlet on the radial centerline of the elbow, and the center-to-contact-surface dimension of the side outlet shall be the same as for the regular 90-deg elbow of the largest opening.

7.1.4 Fittings With Bases. Dimensions of bases for base elbows and base tees are shown in [Tables 7.1.4-1](#) and [7.1.4-2](#).

7.1.5 Special-Degree Elbows. Special-degree elbows ranging from 1 deg to 45 deg, inclusive, shall have the same center-to-contact-surface dimensions as 45-deg elbows; those over 45 deg to 90 deg, inclusive, shall have the same center-to-contact-surface dimensions as 90-deg elbows. The angle designation of an elbow is its deflection from straight-line flow and is also the angle between the flange faces.

7.2 Facings

7.2.1 General. Class 150 fittings and companion flanges are regularly furnished flat or with a 1.5 mm (0.06 in.) raised face. Class 300 fittings and companion

flanges are furnished with a 1.5 mm (0.06 in.) raised face. The raised face is included in the minimum flange thickness dimensions, Q , as given in the tables.

7.2.2 Facings of Blind Flanges. Blind flanges need not be faced in the center if, when this center part is raised, its diameter is at least 25.4 mm (1 in.) smaller than the inside diameter of the corresponding pressure class fittings, as given in the tables. When the center part is depressed, its diameter shall not be greater than the inside diameter of the corresponding pressure-class fittings, as given in the tables. Machining of the depressed center is not required.

7.2.3 Flange Facing Finish. Contact faces shall be finished in accordance with MSS SP-6.

7.3 Flange Bolt Holes

Bolt holes are in multiples of four so that fittings may face in any quadrant. Pairs of bolt holes shall straddle the centerlines as described in [Tables 7.3-1](#) and [7.3-2](#).

7.4 Spot Facing

Spot facing is required on ductile iron flanges and flanges on fittings if the flange thickness at any point does not meet the required minimum thickness, Q , as given in [Tables 7.1.1-1](#), [7.1.1-2](#), [7.4-1](#), and [7.4-2](#) by more than the following amounts:

NPS	Maximum Excess Thickness, mm (in.)
2-18	3 (0.12)
20-24	4.8 (0.19)

Flanges and flanged fittings shall have bearing surfaces for bolting that are parallel to the flange face within 1 deg. Any back facing or spot facing shall not reduce the flange thickness below the minimum. Spot facing or back facing shall be in accordance with MSS SP-9.

7.5 Reducing Flanges

7.5.1 Drilling, Outside Diameter, Thickness, and Facing Dimensions. Flange drilling, outside diameter, thickness, and facing are the same as those of the standard flange of the size from which the reduction is being made.

7.5.2 Threaded Flanges. The hub dimensions shall be at least as large as those of the standard flange of the size from which the reduction is being made. The hub may be larger or may be omitted, as detailed in [Table 7.5.2-1](#).

7.6 Threads for Threaded Flanges

Threaded flanges shall have American National Standard pipe threads, general purpose (inch), conforming to ASME B1.20.1. The thread shall be concentric with the axis of the flange, and variations in alignment shall not exceed 5 mm/m (0.06 in./ft) (0.5%).

7.6.1 Class 150 Flanges. Class 150 flanges are made without a counterbore. The threads shall be chamfered approximately to the major diameter of the thread at the back of the flange at an angle of approximately 45 deg with the axis of the thread, to afford easy entrance in making a joint and to protect the thread. The chamfer shall be concentric with the thread and shall be included in the measurement of the thread length.

7.6.2 Class 300 Flanges. Class 300 flanges may be made with a counterbore. The threads shall be chamfered to the diameter of the counterbore at the back of the flange at an angle of approximately 45 deg with the axis of the threads to afford easy entrance in making a joint. The counterbore and chamfer shall be concentric with the thread.

7.6.3 Length of Threads. The minimum length of effective thread in reducing flanges shall be at least equal to dimension "Length of Thread" of the corresponding pressure class threaded flange as shown in the tables, but does not necessarily extend to the face of the flange. See [Table 7.5.2-1](#) for reducing threaded flanges.

7.6.4 Threading Tolerances. The gaging notch of the working gage shall come flush with the bottom of the chamfer in all threaded flanges, and shall be considered as the intersection of the chamfer cone and the pitch cone of the thread. This depth of chamfer is approximately equal to one-half the pitch of the thread. The maximum allowable thread variation is one turn large or small from the gaging notch.

7.7 Stud Bolts, Bolts, and Nuts

7.7.1 Alloy Bolting. Alloy steel stud bolts, threaded at both ends or full length, or heavy hex bolts may be used. Heavy hex nuts shall be used with all alloy steel bolting.

7.7.2 Carbon Steel Bolting

(a) Bolts smaller than $\frac{3}{4}$ diameter shall have square heads or heavy hex heads. Nuts shall be heavy hex.

(b) Bolts $\frac{3}{4}$ diameter and larger shall have square heads or hex heads. Nuts shall be hex or heavy hex.

7.7.3 Bolt Dimensions. Dimensions of all bolts shall conform to ASME B18.2.1.

7.7.4 Nut Dimensions. Dimensions of all nuts shall conform to ASME B18.2.2.

7.7.5 Threading of Bolts

(a) Carbon steel bolting shall be threaded in accordance with ASME B1.1, coarse thread series, Class 2A for bolts and stud bolts, and Class 2B for nuts.

(b) Alloy steel bolting shall be threaded in accordance with ASME B1.1. Nominal diameters 1 in. and smaller shall be of the coarse thread series; nominal diameters $1\frac{1}{8}$ in. and larger shall be of the 8-thread series. Bolts, studs, and

stud bolts shall have Class 2A dimensions; nuts shall have Class 2B dimensions.

7.8 Gaskets

Gaskets for Class 150 flat face flanges shall conform to the dimensions shown in ASME B16.21. For flanges with raised face, gaskets shall conform to ASME B16.5, [Nonmandatory Appendix B](#), Limiting Dimensions of Gaskets Other Than Ring Joint Gaskets, Group Ia.

7.9 Drains

7.9.1 Pipe Thread Tapping. Holes may be tapped in the wall of a fitting if the metal is thick enough to allow the effective thread length specified in MSS SP-45. Where thread length is insufficient or the tapped hole needs reinforcement, a boss shall be added.

7.9.2 Bosses. Where bosses are required, the diameters shall be as specified in MSS SP-45.

7.9.3 Designating Locations. The means of designating the locations of tapped holes or sockets for drains in fittings is shown in [Figure 7.9.3-1](#).

Each possible location is designated by a letter so that the desired locations for the various types of fittings may be specified without using further sketches or descriptions.

8 TOLERANCES

8.1 Wall Thickness

The wall thickness values for fittings listed in [Tables 7.1.1-1](#) and [7.1.1-2](#) are minimums. Equipment shall be designed to produce greater nominal wall thickness so that manufacturing variances will not fall below these minimum values. See [Nonmandatory Appendix B](#), [para. B-1.2](#) for the basis used to establish these values.

8.2 Center to Contact Surface and Contact Surface to Contact Surface

8.2.1 Center to Contact Surface

- (a) sizes NPS 10 and smaller: ± 0.8 mm (± 0.03 in.)
- (b) sizes NPS 12 and larger: ± 1.5 mm (± 0.06 in.)

8.2.2 Contact Surface to Contact Surface

- (a) sizes NPS 10 and smaller: ± 1.5 mm (± 0.06 in.)
- (b) sizes NPS 12 and larger: ± 3 mm (± 0.12 in.)

8.3 Facings

Outside diameter, 1.5 mm (0.06 in.) raised face: ± 0.8 mm (± 0.03 in.)

8.4 Flange Thickness

- (a) sizes NPS 18 and smaller: $+3$ mm, -0 ($+0.12$ in., -0)

- (b) sizes NPS 20 and larger: $+4.8$ mm, -0 ($+0.19$ in., -0)

8.5 Bore of Flanges

8.5.1 Lapped Flanges

- (a) sizes NPS 10 and smaller: $+0.8$ mm, -0 ($+0.03$ in., -0)
- (b) sizes NPS 12 and larger: $+1.5$ mm, -0 ($+0.06$ in., -0)

8.5.2 Counterbore of Threaded Flanges

- (a) sizes NPS 10 and smaller: $+0.8$ mm, -0 ($+0.03$ in., -0)
- (b) sizes NPS 12 and larger: $+1.5$ mm, -0 ($+0.06$ in., -0)

8.6 Drilling and Facing

- (a) bolt circle diameter: ± 1.5 mm (± 0.06 in.)
- (b) center to center of adjacent bolt holes: ± 0.8 mm (± 0.03 in.)
- (c) eccentricity between bolt circle diameter and machined facing diameters:
 - (1) sizes NPS $2\frac{1}{2}$ and smaller: ± 0.8 mm (± 0.03 in.)
 - (2) sizes NPS 3 and larger: ± 1.5 mm (± 0.06 in.)

9 TESTING

9.1 General

Flanged fittings shall be hydrostatically tested in accordance with [para. 9.3](#).

9.2 Flange Testing

Flanges are not required to be hydrostatically tested. Flanges attached to (or integral with) piping, pressure vessels, or other equipment may be subject to system hydrostatic test (see [para. 3.5.3](#)). In such cases, attention should be given to gasket selection because of possible excessive deformation of the flange.

9.3 Fitting Shell Tests

The hydrostatic shell test for flanged fittings shall be not less than 1.5 times the 38°C (100°F) rating rounded off to the next higher 1.7 bar (25 psi) increment. The test pressure shall be 27.6 bar (400 psi) for Class 150 and 67.2 bar (975 psi) for Class 300.

(a) The test shall be made with water or with other suitable fluid provided its viscosity is no greater than that of water, at a test fluid temperature not above 52°C (125°F).

(b) The test duration shall be a minimum of 15 s for fittings NPS 2 and smaller, 60 s for fittings NPS $2\frac{1}{2}$ through 8, and 3 min for fittings NPS 10 and larger.

(c) No visible leakage is permitted through the pressure boundary wall.

(21) **Table 3.1-1**
Pressure-Temperature Ratings

Temperature, °C	Working Pressure, bar	
	Class 150	Class 300
-29 to 38	17.2	44
50	17.0	43
100	16.0	41
150	14.8	39
200	13.9	36
250	12.1	35
260 [Note (1)]	12.1	35
300	10.2	33
343	8.6	31

NOTE: (1) The maximum temperature for ASTM A536 Grade 65-45-12 is 260°C.

(21) **Table 3.1-1C**
Pressure-Temperature Ratings

Temperature, °F	Working Pressure, psi	
	Class 150	Class 300
-20 to 100	250	640
200	235	600
300	215	565
400	200	525
500 [Note (1)]	170	495
600	140	465
650	125	450

NOTE: (1) The maximum temperature for ASTM A536 Grade 65-45-12 is 500°F.

**Figure 4.2-1
Method of Designating Outlets of Reducing Fittings**

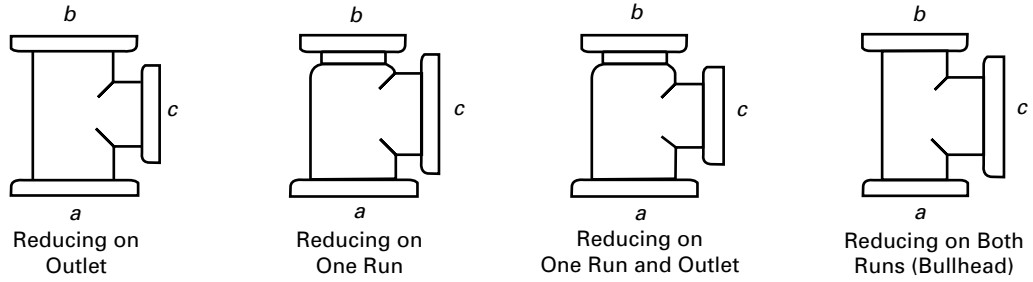

Reducing Tees

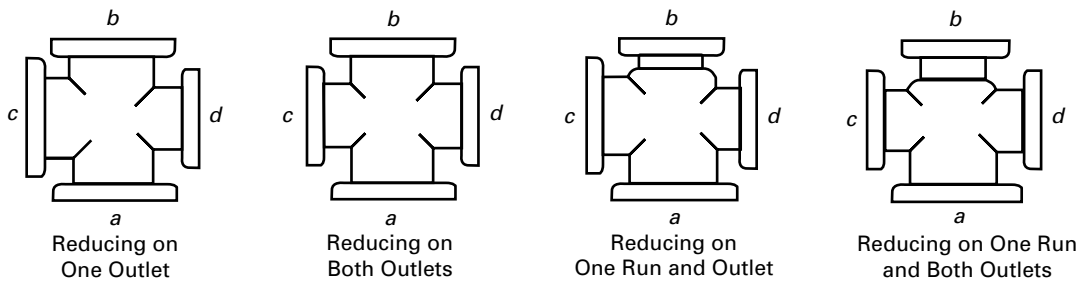

Reducing Crosses

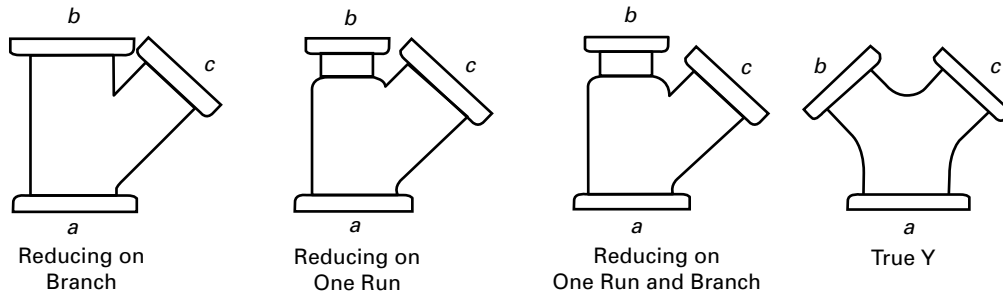

Reducing Laterals

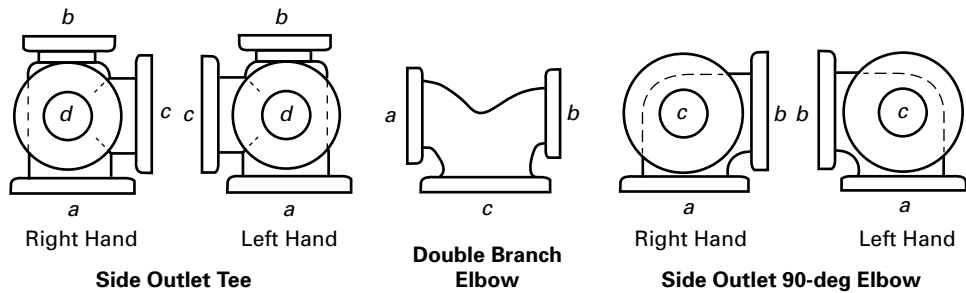

(21)

**Table 7.1.1-1
Dimensions of Class 150 Elbows, Double Branch Elbows, Tees, Crosses, Laterals, True Ys (Straight Sizes), and Reducers**

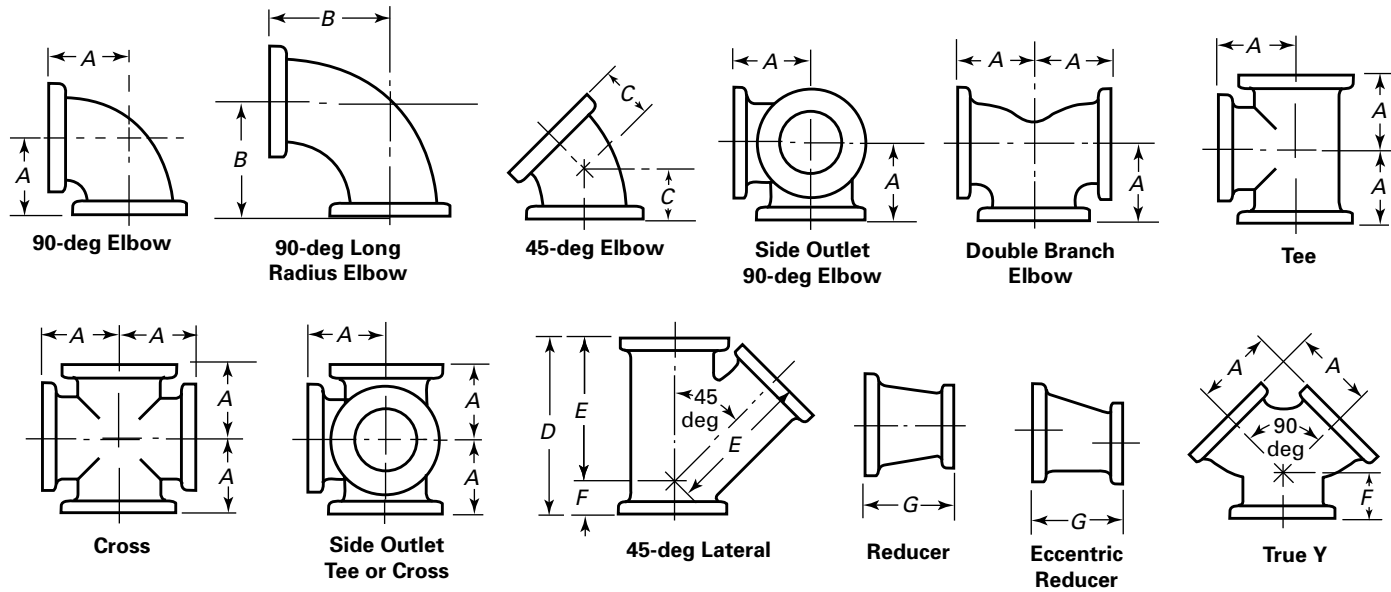

8

NPS	Inside Diameter of Fittings	Center-to-Face 90-deg Elbows, Tees, Crosses, True Y, and Double Branch Elbow, A	Center-to-Face 90-deg Long Radius Elbow, B	Center-to-Face 45-deg Elbow, C	Face-to-Face Lateral, D	Center-to-Face Lateral, E	Short Center-to-Face True Y and Lateral, F	Face-to-Face Reducer, G	Diameter of Flange	Minimum Thickness of Flange, Q	Minimum Body Wall Thickness
1	25 (1.00)	89 (3.50)	127 (5.00)	45 (1.75)	191 (7.50)	146 (5.75)	45 (1.75)	114 (4.50)	106 (4.25)	11.1 (0.44)	4.0 (0.16)
1¼	32 (1.25)	95 (3.75)	140 (5.50)	51 (2.00)	204 (8.00)	159 (6.25)	45 (1.75)	114 (4.50)	118 (4.62)	12.7 (0.50)	4.8 (0.19)
1½	38 (1.50)	102 (4.00)	152 (6.00)	57 (2.25)	229 (9.00)	178 (7.00)	51 (2.00)	114 (4.50)	127 (5.00)	14.3 (0.56)	4.8 (0.19)
2	51 (2.00)	114 (4.50)	165 (6.50)	64 (2.50)	267 (10.50)	203 (8.00)	64 (2.50)	127 (5.00)	152 (6.00)	15.9 (0.62)	5.6 (0.22)
2½	64 (2.50)	127 (5.00)	178 (7.00)	76 (3.00)	305 (12.00)	241 (9.50)	64 (2.50)	140 (5.50)	178 (7.00)	17.5 (0.69)	5.6 (0.22)
3	76 (3.00)	140 (5.50)	197 (7.75)	76 (3.00)	330 (13.00)	254 (10.00)	76 (3.00)	152 (6.00)	191 (7.50)	19.0 (0.75)	5.6 (0.22)
3½	89 (3.50)	152 (6.00)	216 (8.50)	89 (3.50)	368 (14.50)	292 (11.50)	76 (3.00)	165 (6.50)	216 (8.50)	20.6 (0.81)	6.3 (0.25)
4	102 (4.00)	165 (6.50)	229 (9.00)	102 (4.00)	381 (15.00)	305 (12.00)	76 (3.00)	178 (7.00)	229 (9.00)	23.8 (0.94)	6.3 (0.25)
5	127 (5.00)	191 (7.50)	260 (10.25)	114 (4.50)	432 (17.00)	343 (13.50)	89 (3.50)	203 (8.00)	254 (10.00)	23.8 (0.94)	7.1 (0.28)
6	152 (6.00)	203 (8.00)	292 (11.50)	127 (5.00)	457 (18.00)	368 (14.50)	89 (3.50)	229 (9.00)	279 (11.00)	25.4 (1.00)	7.1 (0.28)
8	203 (8.00)	229 (9.00)	356 (14.00)	140 (5.50)	559 (22.00)	445 (17.50)	114 (4.50)	279 (11.00)	343 (13.50)	28.6 (1.12)	7.9 (0.31)
10	254 (10.00)	279 (11.00)	419 (16.50)	165 (6.50)	648 (25.50)	521 (20.50)	127 (5.00)	305 (12.00)	406 (16.00)	30.2 (1.19)	8.6 (0.34)

Table 7.1.1-1
Dimensions of Class 150 Elbows, Double Branch Elbows, Tees, Crosses, Laterals, True Ys (Straight Sizes), and Reducers (Cont'd)

NPS	Inside Diameter of Fittings	Center-to-Face 90-deg Elbows, Tees, Crosses, True Y, and Double Branch Elbow, <i>A</i>	Center-to-Face 90-deg Long Radius Elbow, <i>B</i>	Center-to-Face 45-deg Elbow, <i>C</i>	Face-to-Face Lateral, <i>D</i>	Center-to-Face Lateral, <i>E</i>	Short Center-to-Face True Y and Lateral, <i>F</i>	Face-to-Face Reducer, <i>G</i>	Diameter of Flange	Minimum Thickness of Flange, <i>Q</i>	Minimum Body Wall Thickness
12	305 (12.00)	305 (12.00)	483 (19.00)	191 (7.50)	762 (30.00)	622 (24.50)	140 (5.50)	356 (14.00)	483 (19.00)	31.8 (1.25)	9.5 (0.38)
14	356 (13.25)	356 (14.00)	546 (21.50)	191 (7.50)	838 (33.00)	686 (27.00)	152 (6.00)	406 (16.00)	533 (21.00)	34.9 (1.38)	10.3 (0.41)
16	406 (15.25)	381 (15.00)	610 (24.00)	203 (8.00)	927 (36.50)	762 (30.00)	165 (6.50)	457 (18.00)	597 (23.50)	36.5 (1.44)	11.1 (0.44)
18	457 (17.25)	419 (16.50)	673 (26.50)	216 (8.50)	991 (39.00)	813 (32.00)	178 (7.00)	483 (19.00)	635 (25.00)	39.7 (1.56)	11.9 (0.47)
20	508 (19.25)	457 (18.00)	737 (29.00)	241 (9.50)	1092 (43.00)	889 (35.00)	203 (8.00)	508 (20.00)	699 (27.50)	42.9 (1.69)	12.7 (0.50)
24	610 (23.25)	559 (22.00)	864 (34.00)	279 (11.00)	1258 (49.50)	1029 (40.50)	229 (9.00)	610 (24.00)	813 (32.00)	47.6 (1.88)	14.3 (0.57)

GENERAL NOTES:

- (a) Dimensions are in millimeters (inches).
 (b) For tolerances, see [section 8](#).
 (c) For facings, see [para. 7.2](#).
 (d) For flange bolt holes, see [para. 7.3](#) and [Table 7.3-1](#).
 (e) For spot facing, see [para. 7.4](#).
 (f) For center-to-contact-surface and center-to-end dimensions of reducing fittings, see [para. 7.1](#).
 (g) For contact-surface-to-contact-surface and end-to-end dimensions of reducers and eccentric reducers, see [para. 7.1](#).
 (h) For intersecting centerlines, and center-to-contact-surface and center-to-end dimensions of side-outlet fittings, see [para. 7.1](#).
 (i) For center-to-contact-surface and center-to-end dimensions of special-degree elbows, see [para. 7.1](#).
 (j) For drains, see [para. 7.9](#).

**Table 7.1.1-2
Dimensions of Class 300 Elbows, Tees, Crosses, Laterals, True Ys (Straight Sizes), and Reducers**

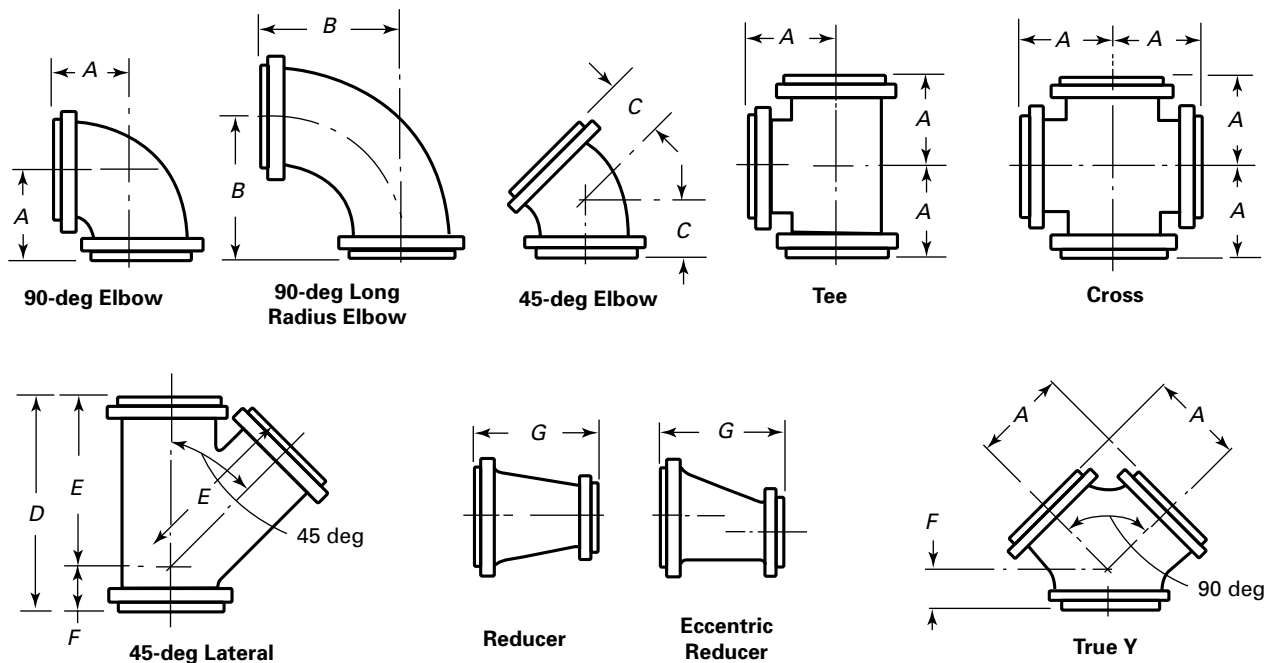

10

NPS	Minimum Inside Diameter of Fittings	Center-to-Face 90-deg Elbows, Tees, Crosses, and True Y, A	Center-to-Face 90-deg Long Radius Elbow, C	Center-to-Face 45-deg Elbow, C	Face-to-Face Lateral, D	Center-to-Face Lateral, E	Short Center- to-Face True Y and Lateral, F	Face-to-Face Reducer, G	Diameter of Flange	Minimum Thickness of Flange, Q	Minimum Body Wall Thickness
1	25 (1.00)	102 (4.00)	127 (5.00)	58 (2.25)	216 (8.50)	165 (6.50)	51 (2.00)	114 (4.50)	124 (4.88)	17.5 (0.69)	4.8 (0.19)
1¼	32 (1.25)	108 (4.25)	140 (5.50)	64 (2.50)	241 (9.50)	184 (7.25)	57 (2.25)	114 (4.50)	133 (5.25)	19.1 (0.75)	4.8 (0.19)
1½	38 (1.50)	114 (4.50)	152 (6.00)	70 (2.75)	280 (11.00)	216 (8.50)	64 (2.50)	114 (4.50)	156 (6.12)	20.6 (0.81)	4.8 (0.19)
2	51 (2.00)	127 (5.00)	165 (6.50)	76 (3.00)	293 (11.50)	229 (9.00)	64 (2.50)	127 (5.00)	165 (6.50)	22.3 (0.88)	6.4 (0.25)
2½	64 (2.50)	140 (5.50)	178 (7.00)	89 (3.50)	331 (13.00)	267 (10.50)	64 (2.50)	140 (5.50)	191 (7.50)	25.4 (1.00)	6.4 (0.25)
3	78 (3.00)	152 (6.00)	197 (7.75)	89 (3.50)	355 (14.00)	279 (11.00)	76 (3.00)	152 (6.00)	210 (8.25)	28.4 (1.12)	7.1 (0.28)
3½	89 (3.50)	165 (6.50)	216 (8.50)	102 (4.00)	394 (15.50)	318 (12.50)	76 (3.00)	165 (6.50)	229 (9.00)	30.2 (1.19)	7.4 (0.29)
4	102 (4.00)	178 (7.00)	229 (9.00)	114 (4.50)	419 (16.50)	343 (13.50)	76 (3.00)	178 (7.00)	254 (10.00)	31.8 (1.25)	7.9 (0.31)
5	127 (5.00)	203 (8.00)	260 (10.25)	127 (5.00)	470 (18.50)	381 (15.00)	89 (3.50)	203 (8.00)	279 (11.00)	35.0 (1.38)	9.6 (0.38)
6	152 (6.00)	216 (8.50)	292 (11.50)	140 (5.50)	547 (21.50)	445 (17.50)	102 (4.00)	229 (9.00)	318 (12.50)	38.6 (1.44)	9.6 (0.38)

**Table 7.1.1-2
Dimensions of Class 300 Elbows, Tees, Crosses, Laterals, True Ys (Straight Sizes), and Reducers (Cont'd)**

NPS	Minimum Inside Diameter of Fittings	Center-to-Face 90-deg Elbows, Tees, Crosses, and True Y, <i>A</i>	Center-to-Face 90-deg Long Radius Elbow, <i>C</i>	Center-to-Face 45-deg Elbow, <i>C</i>	Face-to-Face Lateral, <i>D</i>	Center-to-Face Lateral, <i>E</i>	Short Center-to-Face True Y and Lateral, <i>F</i>	Face-to-Face Reducer, <i>G</i>	Diameter of Flange	Minimum Thickness of Flange, <i>Q</i>	Minimum Body Wall Thickness
8	203 (8.00)	254 (10.00)	356 (14.00)	152 (6.00)	648 (25.50)	521 (20.50)	127 (5.00)	279 (11.00)	381 (15.00)	41.1 (1.62)	11.2 (0.44)
10	254 (10.00)	292 (11.50)	419 (16.50)	178 (7.00)	750 (29.50)	610 (24.00)	140 (5.50)	305 (12.00)	444 (17.50)	47.8 (1.88)	12.7 (0.50)
12	305 (12.00)	330 (13.00)	483 (19.00)	203 (8.00)	851 (33.50)	699 (27.50)	152 (6.00)	356 (14.00)	521 (20.50)	50.8 (2.00)	14.2 (0.56)
14	337 (13.25)	381 (15.00)	546 (21.50)	216 (8.50)	946 (37.50)	787 (31.00)	159 (6.50)	406 (16.00)	584 (23.00)	53.8 (2.12)	15.7 (0.62)
16	387 (15.25)	419 (16.50)	609 (24.00)	241 (9.50)	1067 (42.00)	876 (34.50)	191 (7.50)	457 (18.00)	648 (25.50)	57.2 (2.25)	17.5 (0.69)
18	432 (17.00)	457 (18.00)	673 (26.50)	254 (10.00)	1156 (45.50)	953 (37.50)	203 (8.00)	483 (19.00)	711 (28.00)	60.4 (2.38)	19.1 (0.75)
20	483 (19.00)	495 (19.50)	737 (29.00)	267 (10.50)	1245 (49.00)	1029 (40.50)	216 (8.50)	503 (20.00)	775 (30.50)	63.5 (2.50)	20.6 (0.81)
24	584 (23.00)	572 (22.50)	864 (34.00)	305 (12.00)	1461 (57.50)	1207 (47.50)	254 (10.00)	610 (24.00)	914 (36.00)	69.8 (2.75)	23.9 (0.94)

GENERAL NOTES:

- (a) Dimensions are in millimeters (inches).
 (b) For tolerances, see [section 8](#).
 (c) For facings, see [para. 7.2](#).
 (d) For flange bolt holes, see [para. 7.3](#) and [Table 7.3-2](#).
 (e) For spot facing, see [para. 7.4](#).
 (f) For center-to-contact-surface and center-to-end dimensions of reducing fittings, see [para. 7.1](#).
 (g) For contact-surface-to-contact-surface and end-to-end dimensions of reducers and eccentric reducers, see [para. 7.1](#).
 (h) For intersecting centerlines, and center-to-contact-surface and center-to-end dimensions of side-outlet fittings, see [para. 7.1](#).
 (i) For center-to-contact-surface and center-to-end dimensions of special-degree elbows, see [para. 7.1](#).
 (j) For drains, see [para. 7.9](#).

**Table 7.1.4-1
Dimensions of Class 150 Base Elbows and Base Tees**

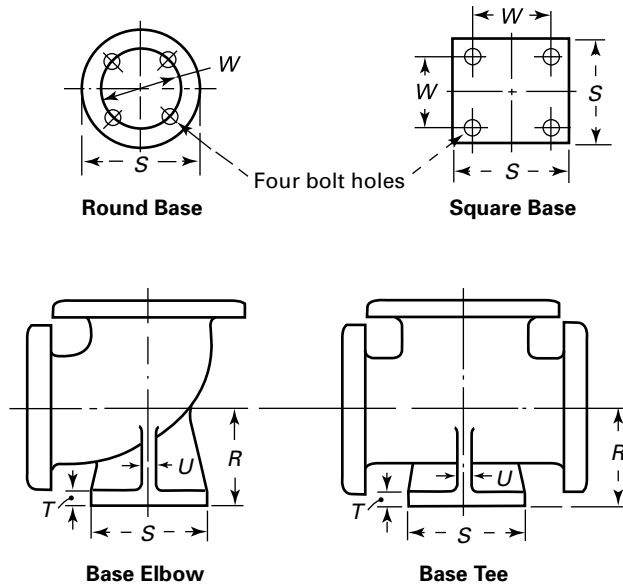

NPS	Center-to-Base, <i>R</i> [Note (1)]	Diameter of Round Base or Width of Square Base, <i>S</i> [Note (2)]		Thickness of Base, <i>T</i>	Thickness of Ribs, <i>U</i>	Nominal Size of Supporting Pipe for Base	Base Drilling [Note (3)]	
							Bolt Circle or Bolt Spacing, <i>W</i>	Diameter of Drilled Holes
2	105 (4.12)	118 (4.62)	13 (0.50)	13 (0.50)	1 1/4	89 (3.50)	15.9 (0.62)	
2 1/2	114 (4.50)	118 (4.62)	13 (0.50)	13 (0.50)	1 1/4	89 (3.50)	15.9 (0.62)	
3	124 (4.88)	127 (5.00)	14 (0.56)	13 (0.50)	1 1/2	98 (3.88)	15.9 (0.62)	
3 1/2	133 (5.25)	127 (5.00)	14 (0.56)	13 (0.50)	1 1/2	98 (3.88)	15.9 (0.62)	
4	140 (5.50)	152 (6.00)	16 (0.62)	13 (0.50)	2	121 (4.75)	19.0 (0.75)	
5	159 (6.25)	178 (7.00)	18 (0.69)	16 (0.62)	2 1/2	140 (5.50)	19.0 (0.75)	
6	178 (7.00)	178 (7.00)	18 (0.69)	16 (0.62)	2 1/2	140 (5.50)	19.0 (0.75)	
8	213 (8.38)	229 (9.00)	24 (0.94)	22 (0.88)	4	191 (7.50)	19.0 (0.75)	
10	248 (9.75)	229 (9.00)	24 (0.94)	22 (0.88)	4	191 (7.50)	19.0 (0.75)	
12	286 (11.25)	279 (11.00)	25 (1.00)	25 (1.00)	6	241 (9.50)	22.2 (0.88)	
14	318 (12.50)	279 (11.00)	25 (1.00)	25 (1.00)	6	241 (9.50)	22.2 (0.88)	
16	349 (13.75)	279 (11.00)	25 (1.00)	25 (1.00)	6	241 (9.50)	22.2 (0.88)	
18	381 (15.00)	343 (13.50)	29 (1.12)	29 (1.12)	8	298 (11.75)	22.2 (0.88)	
20	406 (16.00)	343 (13.50)	29 (1.12)	29 (1.12)	8	298 (11.75)	22.2 (0.88)	
24	470 (18.50)	343 (13.50)	29 (1.12)	29 (1.12)	8	298 (11.75)	22.2 (0.88)	

GENERAL NOTES:

- (a) Dimensions are in millimeters (inches).
- (b) Bases are not finished unless so ordered.

NOTES:

- (1) For reducing fittings, the size and center-to-face dimensions of base are determined by the size of the largest opening of fitting. In the case of reducing base elbows, orders shall specify whether the base shall be opposite the larger or smaller opening.
- (2) The base dimensions apply to all straight and reducing sizes.
- (3) Bolt-hole template shown for round base is the same as for the flange of the supporting pipe size, except using only four holes in all cases, so placed as to straddle centerlines. The bases of these fittings are intended for support in compression and are not to be used for anchors or supports in tension or shear.

**Table 7.1.4-2
Dimensions of Class 300 Base Elbows and Base Tees**

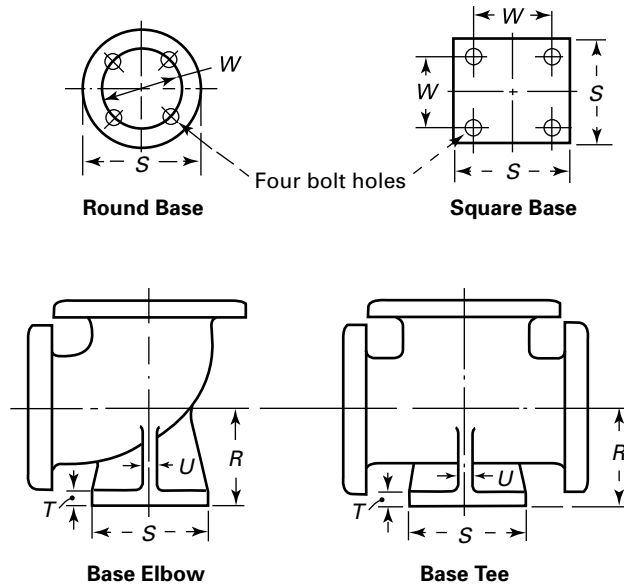

NPS	Center-to-Base, <i>R</i> [Note (1)]	Diameter of Round Base or Width of Square Base, <i>S</i> [Note (2)]		Thickness of Base, <i>T</i>	Thickness of Ribs, <i>U</i>	Nominal Size of Supporting Pipe for Base	Base Drilling [Note (3)]	
							Bolt Circle or Bolt Spacing, <i>W</i>	Diameter of Drilled Holes
2	114 (4.50)	133 (5.25)	133 (5.25)	19 (0.75)	13 (0.50)	1¼	98 (3.88)	19.1 (0.75)
2½	121 (4.75)	133 (5.25)	133 (5.25)	19 (0.75)	13 (0.50)	1¼	98 (3.88)	19.1 (0.75)
3	133 (5.25)	156 (6.12)	156 (6.12)	21 (0.81)	16 (0.62)	1½	114 (4.50)	22.3 (0.88)
3½	143 (5.62)	156 (6.12)	156 (6.12)	21 (0.81)	16 (0.62)	1½	114 (4.50)	22.3 (0.88)
4	152 (6.00)	165 (6.50)	165 (6.50)	22 (0.88)	16 (0.62)	2	127 (5.00)	19.1 (0.75)
5	171 (6.75)	191 (7.50)	191 (7.50)	25 (1.00)	19 (0.75)	2½	149 (5.88)	22.3 (0.88)
6	191 (7.50)	191 (7.50)	191 (7.50)	25 (1.00)	19 (0.75)	2½	149 (5.88)	22.3 (0.88)
8	229 (9.00)	254 (10.00)	254 (10.00)	32 (1.25)	22 (0.88)	4	200 (7.88)	22.3 (0.88)
10	267 (10.50)	254 (10.00)	254 (10.00)	32 (1.25)	22 (0.88)	4	200 (7.88)	22.3 (0.88)
12	305 (12.00)	318 (12.50)	318 (12.50)	36 (1.44)	25 (1.00)	6	270 (10.62)	22.3 (0.88)
14	343 (13.50)	318 (12.50)	318 (12.50)	36 (1.44)	25 (1.00)	6	270 (10.62)	22.3 (0.88)
16	375 (14.75)	318 (12.50)	318 (12.50)	36 (1.44)	28 (1.12)	6	270 (10.62)	22.3 (0.88)
18	413 (16.25)	381 (15.00)	381 (15.00)	41 (1.62)	28 (1.12)	8	330 (13.00)	25.4 (1.00)
20	454 (17.88)	381 (15.00)	381 (15.00)	41 (1.62)	32 (1.25)	8	330 (13.00)	25.4 (1.00)
24	527 (20.75)	445 (17.50)	445 (17.50)	48 (1.88)	32 (1.25)	10	387 (15.25)	28.4 (1.12)

GENERAL NOTES:

- (a) Dimensions are in millimeters (inches).
- (b) Bases are not finished unless so ordered.

NOTES:

- (1) For reducing fittings, the size and center-to-face dimension of base are determined by the size of the largest opening of fitting. In the case of reducing base elbows, orders shall specify whether the base shall be opposite the larger or smaller opening.
- (2) The base dimensions apply to all straight and reducing sizes.
- (3) Bolt-hole template shown for round base is the same as for the flange of the supporting pipe size, except using only four holes in all cases, so placed as to straddle centerlines. The bases of these fittings are intended for support in compression and are not to be used for anchors or supports in tension or shear.

**Table 7.3-1
Templates for Drilling Class 150 Ductile Iron Flanges**

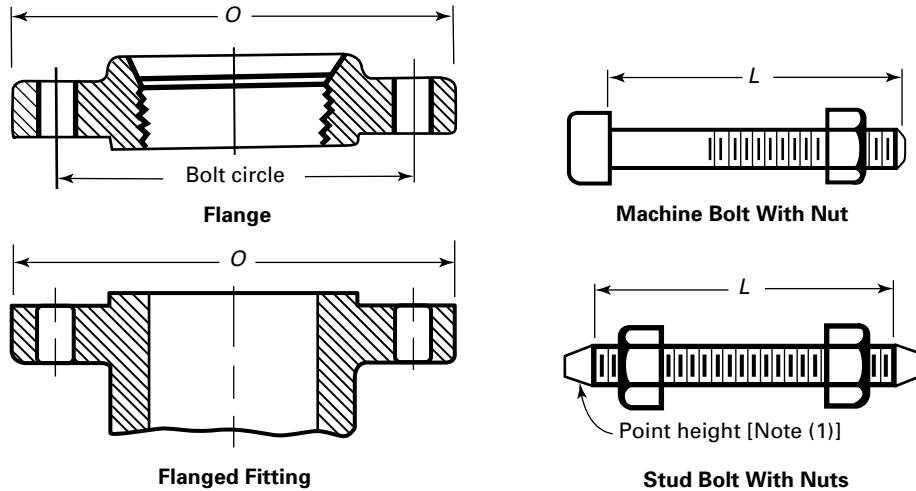

NPS	Outside Diameter of Flange, <i>O</i>	Drilling [Notes (2) and (3)]			Length of Bolts, <i>L</i>		
		Diameter of Bolt Circle	Diameter of Bolt Holes	Number of Bolts	Diameter of Bolts	Stud Bolts [Note (1)]	Machine Bolts
1	110 (4.25)	79.4 (3.12)	$\frac{5}{8}$	4	$\frac{1}{2}$	75 (2.75)	55 (2.25)
1 $\frac{1}{4}$	115 (4.62)	88.9 (3.50)	$\frac{5}{8}$	4	$\frac{1}{2}$	85 (2.75)	55 (2.50)
1 $\frac{1}{2}$	125 (5.00)	98.4 (3.88)	$\frac{5}{8}$	4	$\frac{1}{2}$	85 (3.00)	65 (2.50)
2	150 (6.00)	120.7 (4.75)	$\frac{3}{4}$	4	$\frac{5}{8}$	95 (3.25)	70 (2.75)
2 $\frac{1}{2}$	180 (7.00)	139.7 (5.50)	$\frac{3}{4}$	4	$\frac{5}{8}$	100 (3.50)	75 (3.00)
3	190 (7.50)	152.4 (6.00)	$\frac{3}{4}$	4	$\frac{5}{8}$	100 (3.75)	75 (3.25)
3 $\frac{1}{2}$	215 (8.50)	177.8 (7.00)	$\frac{3}{4}$	8	$\frac{5}{8}$	100 (3.75)	75 (3.25)
4	230 (9.00)	190.5 (7.50)	$\frac{3}{4}$	8	$\frac{5}{8}$	100 (3.75)	75 (3.25)
5	255 (10.00)	215.9 (8.50)	$\frac{7}{8}$	8	$\frac{3}{4}$	110 (4.00)	85 (3.25)
6	280 (11.00)	241.3 (9.50)	$\frac{7}{8}$	8	$\frac{3}{4}$	115 (4.00)	85 (3.50)
8	345 (13.50)	298.5 (11.75)	$\frac{7}{8}$	8	$\frac{3}{4}$	120 (4.25)	90 (3.75)
10	405 (16.00)	362.0 (14.25)	1	12	$\frac{7}{8}$	125 (4.75)	100 (4.00)
12	485 (19.00)	431.8 (17.00)	1	12	$\frac{7}{8}$	135 (4.75)	100 (4.25)
14	535 (21.00)	476.3 (18.75)	1 $\frac{1}{8}$	12	1	145 (5.25)	115 (4.50)
16	595 (23.50)	539.8 (21.25)	1 $\frac{1}{8}$	16	1	145 (5.50)	115 (4.75)
18	635 (25.00)	577.9 (22.75)	1 $\frac{1}{4}$	16	1 $\frac{1}{8}$	160 (6.00)	125 (5.00)
20	700 (27.50)	635.0 (25.00)	1 $\frac{1}{4}$	20	1 $\frac{1}{8}$	170 (6.25)	140 (5.50)
24	815 (32.00)	749.3 (29.50)	1 $\frac{3}{8}$	20	1 $\frac{1}{4}$	185 (7.00)	150 (6.00)

GENERAL NOTES:

- (a) Dimensions are in millimeters (inches) except for diameters of bolts and bolt holes, which are in inches.
- (b) For other dimensions, see [Tables 7.1.1-1](#) and [7.4-1](#).

NOTES:

- (1) Length of stud bolts does not include the height of the points.
- (2) For flange bolt holes, see [para. 7.3](#).
- (3) For spot facing, see [para. 7.4](#).

**Table 7.3-2
Templates for Drilling Class 300 Ductile Iron Flanges**

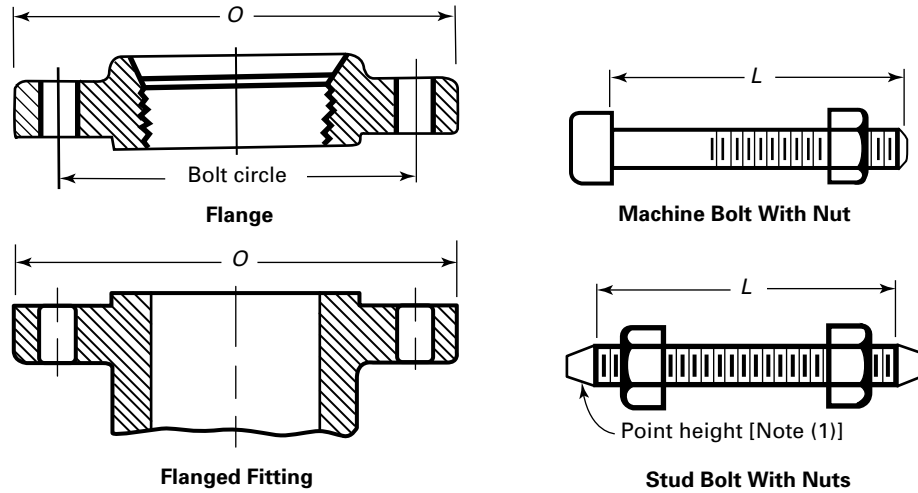

NPS	Outside Diameter of Flange, <i>O</i>	Drilling [Notes (2) and (3)]			Length of Bolts, <i>L</i>		
		Diameter of Bolt Circle	Diameter of Bolt Holes	Number of Bolts	Diameter of Bolts	Stud Bolts [Note (1)]	Machine Bolts
1	125 (4.88)	88.9 (3.50)	3/4	4	5/8	75 (3.00)	65 (2.50)
1 1/4	135 (5.25)	98.4 (3.88)	3/4	4	5/8	85 (3.25)	70 (2.75)
1 1/2	155 (6.12)	114.3 (4.50)	7/8	4	3/4	90 (3.50)	75 (3.00)
2	165 (6.50)	127.0 (5.00)	3/4	8	5/8	90 (3.50)	75 (3.00)
2 1/2	190 (7.50)	149.2 (5.88)	7/8	8	3/4	100 (4.00)	85 (3.25)
3	210 (8.25)	168.3 (6.62)	7/8	8	3/4	110 (4.25)	90 (3.50)
3 1/2	230 (9.00)	184.2 (7.25)	7/8	8	3/4	110 (4.25)	95 (3.75)
4	255 (10.00)	200.0 (7.88)	7/8	8	3/4	115 (4.50)	95 (3.75)
5	280 (11.00)	235.0 (9.25)	7/8	8	3/4	120 (4.75)	110 (4.25)
6	320 (12.50)	269.9 (10.62)	7/8	12	3/4	120 (4.75)	110 (4.25)
8	380 (15.00)	330.2 (13.00)	1	12	7/8	140 (5.50)	120 (4.75)
10	445 (17.50)	387.4 (15.25)	1 1/8	16	1	160 (6.25)	140 (5.50)
12	520 (20.50)	450.8 (17.75)	1 1/4	16	1 1/8	170 (6.75)	145 (5.75)
14	585 (23.00)	514.4 (20.25)	1 1/4	20	1 1/8	180 (7.00)	160 (6.25)
16	650 (25.50)	571.5 (22.50)	1 3/8	20	1 1/4	190 (7.50)	165 (6.50)
18	710 (28.00)	628.6 (24.75)	1 3/8	24	1 1/4	195 (7.75)	170 (6.75)
20	775 (30.50)	685.8 (27.00)	1 3/8	24	1 1/4	205 (8.00)	185 (7.25)
24	915 (36.00)	812.8 (32.00)	1 1/2	24	1 1/2	230 (9.00)	205 (8.00)

GENERAL NOTES:

- (a) Dimensions are in millimeters (inches) except for diameters of bolts and bolt holes, which are in inches.
- (b) For other dimensions, see Tables 7.1.1-2 and 7.4-2.

NOTES:

- (1) Length of stud bolts does not include the height of the points.
- (2) For flange bolt holes, see para. 7.3.
- (3) For spot facing, see para. 7.4.

Table 7.4-1
Dimensions of Class 150 Ductile Iron Flanges

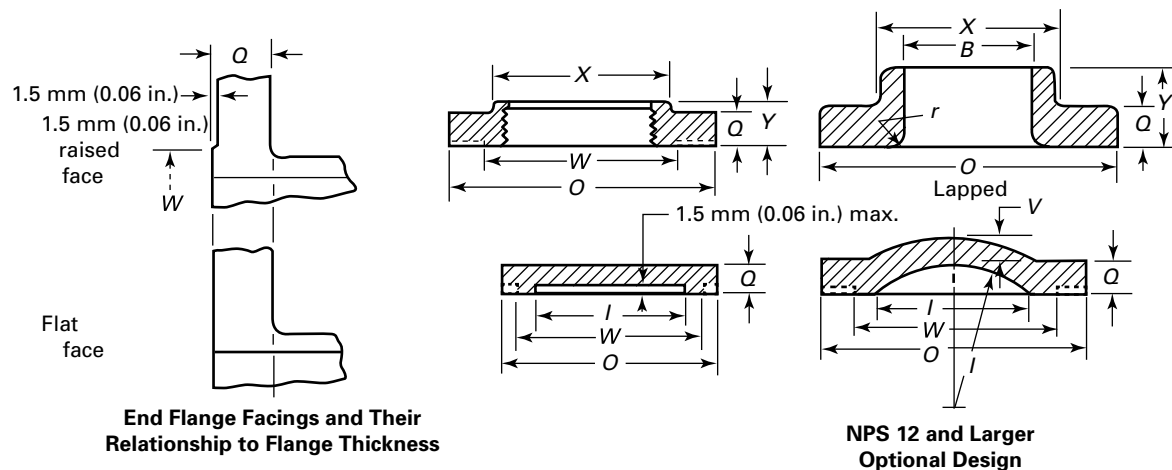

NPS	Diameter of Port, I	Diameter of Flange, O	Minimum Thickness of Flange, Q	Minimum Diameter of Hub, X [Note (1)]	Minimum Length of Hub and Threads, Y [Note (2)]	Minimum Domed Wall Thickness, V	Diameter of Raised Face, W	Minimum Bore Lapped, B	Corner Radius of Bore of Lapped Flange, r	Hub Length Lapped, Y
1	25 (1.00)	110 (4.25)	14.2 (0.56)	49 (1.94)	18 (0.69)	...	51 (2.00)	35 (1.38)	4 (0.12)	17 (0.69)
1 $\frac{1}{4}$	32 (1.25)	115 (4.62)	15.7 (0.62)	59 (2.31)	21 (0.81)	...	64 (2.50)	44 (1.72)	5 (0.19)	21 (0.81)
1 $\frac{1}{2}$	38 (1.50)	125 (5.00)	17.5 (0.69)	65 (2.56)	22 (0.88)	...	73 (2.88)	50 (1.97)	6 (0.25)	22 (0.88)
2	51 (2.00)	150 (6.00)	19.0 (0.75)	78 (3.06)	25 (1.00)	...	92 (3.62)	62 (2.46)	8 (0.31)	25 (1.00)
2 $\frac{1}{2}$	64 (2.50)	180 (7.00)	22.3 (0.88)	91 (3.56)	29 (1.12)	...	105 (4.12)	75 (2.97)	8 (0.31)	29 (1.12)
3	76 (3.00)	190 (7.50)	23.8 (0.94)	108 (4.25)	30 (1.19)	...	127 (5.00)	91 (3.60)	10 (0.38)	30 (1.19)
3 $\frac{1}{2}$	89 (3.50)	215 (8.50)	23.8 (0.94)	122 (4.81)	32 (1.25)	...	140 (5.50)	104 (4.10)	10 (0.38)	32 (1.25)
4	102 (4.00)	230 (9.00)	23.8 (0.94)	135 (5.31)	33 (1.31)	...	157 (6.19)	117 (4.60)	11 (0.44)	33 (1.31)
5	127 (5.00)	255 (10.00)	23.8 (0.94)	164 (6.44)	37 (1.44)	...	186 (7.31)	144 (5.69)	11 (0.44)	36 (1.44)
6	152 (6.00)	280 (11.00)	25.4 (1.00)	192 (7.56)	40 (1.56)	...	216 (8.50)	172 (6.75)	13 (0.50)	40 (1.56)
8	203 (8.00)	345 (13.50)	28.6 (1.12)	246 (9.69)	44 (1.75)	...	270 (10.62)	222 (8.75)	13 (0.50)	44 (1.75)
10	254 (10.00)	405 (16.00)	30.2 (1.19)	303 (12.00)	49 (1.94)	...	324 (12.75)	277 (10.92)	13 (0.50)	49 (1.94)
12	305 (12.00)	485 (19.00)	31.8 (1.25)	357 (14.38)	56 (2.19)	20.6 (0.81)	381 (15.00)	328 (12.92)	13 (0.50)	56 (2.19)
14	356 (14.00)	535 (21.00)	35.0 (1.38)	391 (15.75)	57 (2.25)	22.2 (0.88)	413 (16.25)	360 (14.18)	13 (0.50)	79 (3.12)
16	406 (16.00)	595 (23.50)	36.5 (1.44)	445 (18.00)	64 (2.50)	25.4 (1.00)	470 (18.50)	419 (16.19)	13 (0.50)	87 (3.44)
18	457 (18.00)	635 (25.00)	39.7 (1.56)	499 (19.88)	68 (2.69)	27.0 (1.06)	533 (21.00)	462 (18.20)	13 (0.50)	97 (3.81)

**Table 7.4-1
Dimensions of Class 150 Ductile Iron Flanges (Cont'd)**

NPS	Diameter of Port, <i>I</i>	Diameter of Flange, <i>O</i>	Minimum Thickness of Flange, <i>Q</i>	Minimum Diameter of Hub, <i>X</i> [Note (1)]	Minimum Length of Hub and Threads, <i>Y</i> [Note (2)]	Minimum Domed Wall Thickness, <i>V</i>	Diameter of Raised Face, <i>W</i>	Minimum Bore Lapped, <i>B</i>	Corner Radius of Bore of Lapped Flange, <i>r</i>	Hub Length Lapped, <i>Y</i>
20	508 (20.00)	700 (27.50)	42.9 (1.69)	553 (22.00)	73 (2.88)	28.6 (1.12)	584 (23.00)	514 (20.25)	13 (0.50)	103 (4.06)
24	610 (24.00)	815 (32.00)	47.6 (1.88)	660 (26.12)	83 (3.25)	31.8 (1.25)	692 (27.25)	616 (24.25)	13 (0.50)	111 (4.38)

GENERAL NOTES:

- (a) Dimensions are in millimeters (inches).
- (b) For tolerances, see [section 8](#).
- (c) For facings, see [para. 7.2](#).
- (d) For flange bolt holes, see [para. 7.3](#) and [Table 7.3-1](#).
- (e) For spot facing, see [para. 7.4](#).
- (f) For reducing threaded flanges, see [Table 7.5.2-1](#).
- (g) Blind flanges may be made with or without hubs at the option of the manufacturer.

NOTES:

- (1) This dimension is for large end of the hub, which may be straight or tapered. Taper shall not exceed 7 deg on threaded and lapped flanges.
- (2) For threads of threaded flanges, see [para. 7.6](#).

Table 7.4-2
Dimensions of Class 300 Ductile Iron Flanges

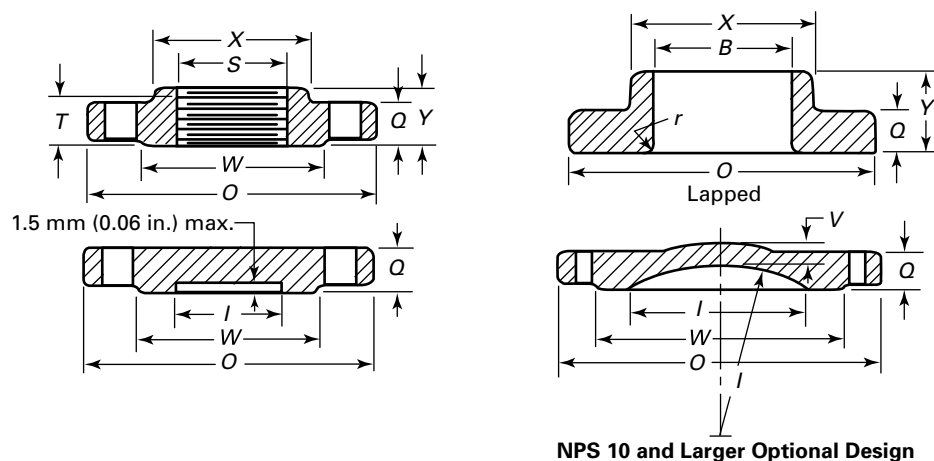

NPS 10 and Larger Optional Design

NPS	Diameter of Port, <i>I</i>	Diameter of Flange, <i>O</i>	Minimum Thickness of Flange, <i>Q</i>	Minimum Diameter of Hub, <i>X</i> [Note (1)]	Minimum Length of Hub, <i>Y</i>	Hub Lapped, <i>Y</i>	Minimum Domed Wall Thickness, <i>V</i>	Minimum Length of Threads, <i>T</i> [Note (2)]	Minimum Bore Lapped, <i>B</i>	Corner Radius of Bore of Lapped Flange, <i>r</i>	Diameter of Raised Face, <i>W</i>	Diameter of Counterbore, <i>S</i>
1	25 (1.00)	125 (4.88)	17.5 (0.69)	52 (2.06)	27 (1.06)	27 (1.06)	...	18 (0.69)	35 (1.38)	3 (0.12)	51 (2.00)	36 (1.41)
1¼	32 (1.25)	135 (5.25)	19.1 (0.75)	64 (2.50)	27 (1.06)	27 (1.06)	...	21 (0.81)	44 (1.72)	5 (0.19)	64 (2.50)	44 (1.75)
1½	38 (1.50)	155 (6.12)	20.6 (0.81)	70 (2.75)	30 (1.19)	30 (1.19)	...	22 (0.88)	51 (1.97)	6 (0.25)	73 (2.88)	51 (1.99)
2	51 (2.00)	165 (6.50)	22.3 (0.88)	84 (3.31)	33 (1.31)	33 (1.31)	...	29 (1.12)	62 (2.46)	8 (0.31)	92 (3.62)	64 (2.50)
2½	64 (2.50)	190 (7.50)	25.4 (1.00)	100 (3.94)	38 (1.50)	38 (1.50)	...	32 (1.25)	75 (2.97)	8 (0.31)	105 (4.12)	76 (3.00)
3	76 (3.00)	210 (8.25)	28.4 (1.12)	117 (4.62)	43 (1.69)	43 (1.69)	...	32 (1.25)	91 (3.60)	10 (0.38)	127 (5.00)	92 (3.63)
3½	89 (3.50)	230 (9.00)	30.2 (1.19)	133 (5.25)	44 (1.75)	44 (1.75)	...	36 (1.44)	104 (4.10)	10 (0.38)	140 (5.50)	105 (4.13)
4	102 (4.00)	255 (10.00)	31.8 (1.25)	146 (5.75)	48 (1.88)	48 (1.88)	...	36 (1.44)	117 (4.60)	11 (0.44)	157 (6.19)	118 (4.63)
5	127 (5.00)	280 (11.00)	35.0 (1.38)	178 (7.00)	51 (2.00)	51 (2.00)	...	43 (1.69)	144 (5.69)	11 (0.44)	186 (7.31)	144 (5.69)
6	152 (6.00)	320 (12.50)	36.6 (1.44)	206 (8.12)	52 (2.06)	52 (2.06)	...	46 (1.81)	172 (6.75)	13 (0.50)	216 (8.50)	172 (6.75)
8	203 (8.00)	380 (15.00)	41.1 (1.62)	260 (10.25)	62 (2.44)	62 (2.44)	...	51 (2.00)	222 (8.75)	13 (0.50)	270 (10.62)	222 (8.75)
10	254 (10.00)	445 (17.50)	47.8 (1.88)	321 (12.62)	67 (2.62)	95 (3.75)	23.9 (0.94)	56 (2.19)	277 (10.92)	13 (0.50)	324 (12.75)	276 (10.88)
12	305 (12.00)	520 (20.50)	50.8 (2.00)	375 (14.75)	73 (2.88)	102 (4.00)	25.4 (1.00)	60 (2.38)	328 (12.92)	13 (0.50)	381 (15.00)	329 (12.94)
14	337 (13.25)	585 (23.00)	53.8 (2.12)	425 (16.75)	76 (3.00)	111 (4.38)	28.6 (1.12)	64 (2.50)	360 (14.18)	13 (0.50)	413 (16.25)	360 (14.19)
16	387 (15.25)	650 (25.50)	57.2 (2.25)	467 (19.00)	83 (3.25)	121 (4.75)	31.8 (1.25)	68 (2.69)	411 (16.19)	13 (0.50)	470 (18.50)	411 (16.19)
18	432 (17.00)	710 (28.00)	60.4 (2.38)	533 (21.00)	89 (3.50)	130 (5.12)	34.9 (1.38)	70 (2.75)	462 (18.20)	13 (0.50)	533 (21.00)	462 (18.19)

**Table 7.4-2
Dimensions of Class 300 Ductile Iron Flanges (Cont'd)**

NPS	Diameter of Port, <i>I</i>	Diameter of Flange, <i>O</i>	Minimum Thickness of Flange, <i>Q</i>	Minimum Diameter of Hub, <i>X</i> [Note (1)]	Minimum Length of Hub, <i>Y</i>	Hub Lapped, <i>Y</i>	Minimum Domed Wall Thickness, <i>V</i>	Minimum Length of Threads, <i>T</i> [Note (2)]	Minimum Bore Lapped, <i>B</i>	Corner Radius of Bore of Lapped Flange, <i>r</i>	Diameter of Raised Face, <i>W</i>	Diameter of Counterbore, <i>S</i>
20	438 (19.00)	775 (30.50)	63.5 (2.50)	587 (23.12)	95 (3.75)	140 (5.50)	38.1 (1.50)	73 (2.88)	514 (20.25)	13 (0.50)	584 (23.00)	513 (20.19)
24	584 (23.00)	915 (36.00)	69.8 (2.75)	702 (27.62)	106 (4.19)	152 (6.00)	41.3 (1.62)	83 (3.25)	616 (24.25)	13 (0.50)	692 (27.25)	614 (24.19)

GENERAL NOTES:

- (a) Dimensions are in millimeters (inches).
- (b) For tolerances, see [section 8](#).
- (c) For facings, see [para. 7.2](#).
- (d) For flange bolt holes, see [para. 7.3](#) and [Table 7.3-2](#).
- (e) For spot facing, see [para. 7.4](#).
- (f) For reducing threaded flanges, see [Table 7.5.2-1](#).
- (g) Blind flanges may be made with or without hub at the option of the manufacturer.

NOTES:

- (1) This dimension is for large end of hub, which may be straight or tapered. Taper shall not exceed 7 deg on threaded and lapped flanges.
- (2) For threads of threaded flanges, see [para. 7.6](#).

**Table 7.5.2-1
Reducing Threaded Flanges for Classes 150 and 300**

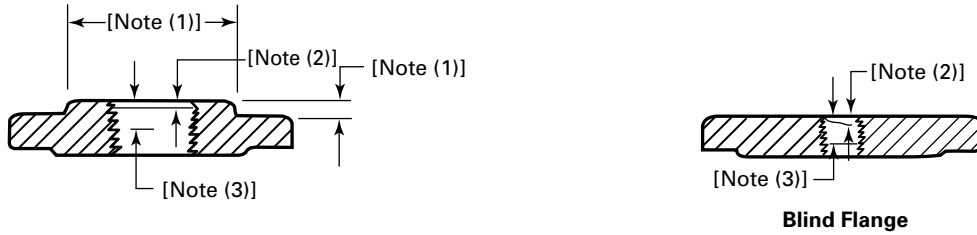

NPS [Note (4)]	Smallest Size of Reducing Outlet Requiring Hub Flanges [Note (1)]	NPS [Note (4)]	Smallest Size of Reducing Outlet Requiring Hub Flanges [Note (1)]	NPS [Note (4)]	Smallest Size of Reducing Outlet Requiring Hub Flanges [Note (1)]
1	1/2	3 1/2	1 1/2	12	3 1/2
1 1/4	1/2	4	1 1/2	14	3 1/2
1 1/2	1/2	5	1 1/2	16	4
2	1	6	2 1/2	18	4
2 1/2	1 1/4	8	3	20	4
3	1 1/4	10	3 1/2	24	4

NOTES:

- (1) The hub dimensions shall be at least as large as those of the standard flanges of the size to which the reduction is being made, except flanges reducing to a size smaller than those shown in this column may be made from blind flanges. See [example \(2\)](#) below.
- (2) Class 150 flanges do not have a counterbore. Class 300 flanges will have a depth of counterbore of 7 mm (0.25 in.) for NPS 2 and smaller tappings and 9.50 mm (0.38 in.) for NPS 2 1/2 and larger. The diameter of counterbore, S, is the same as that given in the tables of threaded flanges for the corresponding tapping.
- (3) The minimum length of effective threads shall be at least equal to dimension “Length of Thread” of the corresponding pressure class threaded flange as shown in the tables, but does not necessarily extend to the face of the flange. For threads of threaded flanges, see [para. 7.6](#).
- (4) For method of designating reducing threaded flanges, see [para. 4.3](#) and [examples \(1\)](#) and [\(2\)](#) below.

EXAMPLES:

- (1) The size designation is NPS 6 × 2 1/2 — Class 300 reducing threaded flange. This flange has the following dimensions:
 - (a) NPS 2 1/2, taper pipe thread tapping (ASME B1.20.1)
 - (b) 320 mm (12.5 in.), diameter of regular NPS 6 Class 300 threaded flange
 - (c) 35 mm (1.44 in.), thickness of regular NPS 6 Class 300 threaded flange
 - (d) 180 mm (7.0 in.), diameter of hub for regular NPS 5 Class 300 threaded flange
 - (e) 15.5 mm (0.62 in.), height of hub for regular NPS 5 Class 300 threaded flange
 Other dimensions are the same as for regular NPS 6 Class 300 threaded flange; see [Table 7.4-2](#).
- (2) The size designation is NPS 6 × 2 — Class 300 reducing threaded flange. Use regular NPS 6 Class 300 blind flange tapped with NPS 2 taper pipe thread (ASME B1.20.1).

Figure 7.9.3-1
Method of Designating Location of Tapped Holes for Drains When Specified

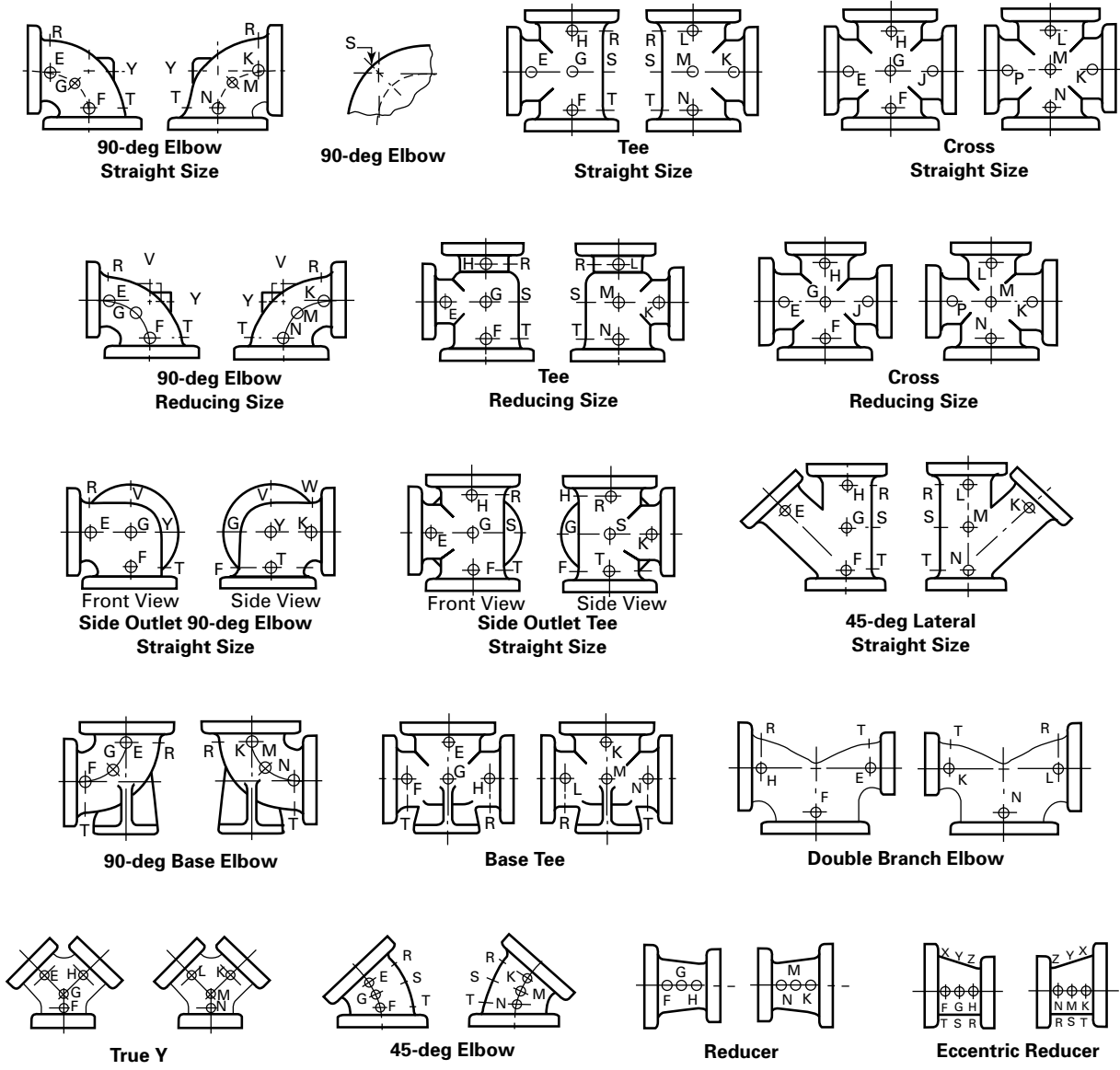

MANDATORY APPENDIX I

REFERENCES

(21)

The following is a list of publications referenced in this Standard. Unless otherwise stated, the latest edition of ASME publications shall apply. Materials manufactured to other editions of a referenced ASTM standard shall be permitted to be used to manufacture flanges and flanged fittings meeting the requirements of this Standard, provided the fitting manufacturer verifies the material meets the requirements of the referenced edition.

- ASME B1.1, Unified Inch Screw Threads (UN and UNR Thread Form)
- ASME B1.20.1, Pipe Threads, General Purpose (Inch)
- ASME B16.5, Pipe Flanges and Flanged Fittings (NPS ½ Through NPS 24 Metric/Inch Standard)
- ASME B16.21, Nonmetallic Flat Gaskets for Pipe Flanges
- ASME B18.2.1, Square, Hex, Heavy Hex, and Askew Head Bolts and Hex, Heavy Hex, Hex Flange, Lobed Head, and Lag Screws (Inch Series)
- ASME B18.2.2, Nuts for General Applications: Machine Screw Nuts, Hex, Square, Hex Flange, and Coupling Nuts (Inch Series)
- ASME Boiler and Pressure Vessel Code, Section I, Power Boilers
- ASME PCC-1, Guidelines for Pressure Boundary Bolted Flange Joint Assembly
- Publisher: The American Society of Mechanical Engineers (ASME), Two Park Avenue, New York, NY 10016-5990 (www.asme.org)
- ASTM A193/A193M-20, Specification for Alloy Steel and Stainless Steel Bolting Materials for High-Temperature Service
- ASTM A194/A194M-20, Specification for Carbon and Alloy Steel Nuts for Bolts for High-Pressure and High-Temperature Service
- ASTM A307-14^{ε1}, Specification for Carbon Steel Bolts and Studs, 60 000 PSI Tensile Strength
- ASTM A395/A395M-99 (2018), Specification for Ferritic Ductile Iron Pressure-Retaining Castings for Use at Elevated Temperatures
- ASTM E29-13 (2019), Standard Practice for Using Significant Digits in Test Data to Determine Conformance with Specifications
- Publisher: American Society for Testing and Materials (ASTM International), 100 Barr Harbor Drive, P.O. Box C700, West Conshohocken, PA 19428-2959 (www.astm.org)
- ISO 9000:2015, Quality management systems — Fundamentals and vocabulary
- ISO 9001:2015, Quality management systems — Requirements¹
- ISO 9004:2018, Quality management — Quality of an organization — Guidance to achieve sustained success¹
- Publisher: International Organization for Standardization (ISO), Central Secretariat, Chemin de Blandonnet 8, Case Postale 401, 1214 Vernier, Geneva, Switzerland (www.iso.org)
- MSS SP-6-2017, Standard Finishes for Contact Faces of Pipe Flanges and Connecting-End Flanges of Valves and Fittings
- MSS SP-9-2018, Spot Facing for Bronze, Iron and Steel Flanges
- MSS SP-25-2018, Standard Marking System for Valves, Fittings, Flanges and Unions
- MSS SP-45-2020 Bypass and Drain Connections
- Publisher: Manufacturers Standardization Society of the Valve and Fittings Industry, Inc. (MSS), 127 Park Street, NE, Vienna, VA 22180 (www.msshq.org)

¹ May also be obtained from American National Standards Institute (ANSI), 25 West 43rd Street, New York, NY 10036.

NONMANDATORY APPENDIX A QUALITY SYSTEM PROGRAM

The products manufactured in accordance with this Standard shall be produced under a quality system program following the principles of an appropriate standard from the ISO 9000 series.¹ A determination of the need for registration and/or certification of the product manufacturer's quality system program by an independent organization shall be the responsibility of the manufacturer. The detailed documentation demon-

strating program compliance shall be available to the purchaser at the manufacturer's facility. A written summary description of the program utilized by the product manufacturer shall be available to the purchaser upon request. The product manufacturer is defined as the entity whose name or trademark appears on the product in accordance with the marking or identification requirements of this Standard.

¹ The series is also available from the American National Standards Institute (ANSI) and the American Society for Quality (ASQ) as American National Standards that are identified by the prefix "Q" replacing the prefix "ISO." ISO 9001 is listed under References in [Mandatory Appendix I](#).

NONMANDATORY APPENDIX B

METHODS FOR ESTABLISHING PRESSURE-TEMPERATURE RATINGS

B-1 GENERAL

B-1.1 Introduction

Pressure-temperature ratings in this Standard have been determined by the procedures in this Appendix. The primary consideration in establishing ratings is adequate wall thickness to sustain stresses due to pressure and other loadings (see [para. B-1.2](#)). Other considerations affecting or limiting the ratings include the following:

- (a) stresses in flanges resulting from bolt-up necessary to maintain gasket seal
- (b) distortion of flanges and flanged fittings due to loadings transmitted through the pipeline
- (c) limitations applying primarily to valves but imposed also on flanges to maintain compatible ratings

B-1.2 Wall Thickness

Wall thickness requirements for flanged fittings are set forth in [para. 8.1](#), and minimum thicknesses, t_m , are listed in the tables designated in [para. 8.1](#). These values are all greater than those determined by [eq. \(1\)](#).

$$t = 1.5P_c d / (2S - 1.2P_c) \quad (1)$$

where

- d = inside diameter of the fitting, in.
- P_c = pressure rating class designation expressed in pounds per square inch (e.g., $P_c = 150$ psi for Class 150)
- S = stress factor of 7,000 psi
- t = calculated thickness, in.

[Equation \(1\)](#) gives a thickness 50% greater than for a simple cylinder designed for a stress of 7,000 psi when subjected to an internal pressure equal to the pressure rating class designation in pounds per square inch. Actual values in the dimension tables listed in [para. 8.1](#) are approximately 0.1 in. to 0.2 in. heavier than those given by the equation.

B-2 RATINGS IN CUSTOMARY UNITS

B-2.1 Ambient Rating Equation

Ratings for -20°F to 100°F temperatures for all pressure classes are established by [eq. \(2\)](#).

$$P_T = P_r S_1 / 8,750 \quad (2)$$

where

- P_r = pressure rating class index expressed in pounds per square inch ($P_r = 300$ psi for Class 300 and $P_r = 150$ psi for Class 150)
- P_T = rated working pressure, psig, for the material at temperature, T
- S_1 = selected stress, psi

The selected stress, S_1 , shall be the lower of the following values:

- (a) 60% of specified minimum yield strength at 100°F
- (b) 31% of specified minimum tensile strength

B-2.2 Ratings for Class 150

Pressure-temperature ratings for Class 150 flanges and flanged fittings are determined as follows:

- (a) The value for P_T at temperature, T ($^\circ\text{F}$), for temperatures from 400°F to 650°F shall be that given by [eq. \(3\)](#).

$$P_T = 320 - 0.3T \quad (3)$$

The limits of T are 400°F minimum and 650°F maximum.

- (b) The values for P_T between 100°F and 400°F shall be determined by linear interpolation of the values calculated for P_T at 100°F using [eqs. \(2\)](#) and [\(3\)](#).

B-2.3 Ratings for Class 300

Pressure-temperature ratings for Class 300 flanges and flanged fittings are determined as follows:

- (a) The value for P_T at temperature, T ($^\circ\text{F}$), for temperatures from 400°F to 650°F shall be that given by [eq. \(4\)](#).

$$P_T = 645 - 0.3T \quad (4)$$

The limits of T are 400°F minimum and 650°F maximum.

- (b) The values for P_T between 100°F and 400°F shall be determined by linear interpolation of the values calculated for P_T at 100°F and 400°F using [eqs. \(2\)](#) and [\(4\)](#).

B16 AMERICAN NATIONAL STANDARDS FOR PIPING, PIPE FLANGES, FITTINGS, AND VALVES

B16.1-2020	Gray Iron Pipe Flanges and Flanged Fittings: Classes 25, 125, and 250
B16.3-2021	Malleable Iron Threaded Fittings: Classes 150 and 300
B16.4-2021	Gray Iron Threaded Fittings: Classes 125 and 250
B16.5-2020	Pipe Flanges and Flanged Fittings: NPS ½ Through NPS 24 Metric/Inch Standard
B16.9-2018	Factory-Made Wrought Butt Welding Fittings
B16.10-2017	Face-to-Face and End-to-End Dimensions of Valves
B16.11-2016	Forged Fittings, Socket-Welding and Threaded
B16.12-2019	Cast Iron Threaded Drainage Fittings
B16.14-2018	Ferrous Pipe Plugs, Bushings, and Locknuts With Pipe Threads
B16.15-2018	Cast Copper Alloy Threaded Fittings
B16.18-2018	Cast Copper Alloy Solder Joint Pressure Fittings
B16.20-2017	Metallic Gaskets for Pipe Flanges
B16.21-2021	Nonmetallic Flat Gaskets for Pipe Flanges
B16.22-2018	Wrought Copper and Copper Alloy Solder-Joint Pressure Fittings
B16.23-2016	Cast Copper Alloy Solder Joint Drainage Fittings: DWV
B16.24-2016	Cast Copper Alloy Pipe Flanges, Flanged Fittings, and Valves: Classes 150, 300, 600, 900, 1500, and 2500
B16.25-2017	Butt Welding Ends
B16.26-2018	Cast Copper Alloy Fittings for Flared Copper Tubes
B16.29-2017	Wrought Copper and Wrought Copper Alloy Solder-Joint Drainage Fittings — DWV
B16.33-2012 (R2017)	Manually Operated Metallic Gas Valves for Use in Gas Piping Systems Up to 175 psi (Sizes NPS ½ Through NPS 2)
B16.34-2020	Valves — Flanged, Threaded, and Welding End
B16.36-2020	Orifice Flanges
B16.38-2012 (R2017)	Large Metallic Valves for Gas Distribution: Manually Operated, NPS 2½ (DN 65) to NPS 12 (DN 300), 125 psig (8.6 bar) Maximum
B16.39-2019	Malleable Iron Threaded Pipe Unions: Classes 150, 250, and 300
B16.40-2019	Manually Operated Thermoplastic Gas Shutoffs and Valves in Gas Distribution Systems
B16.42-2021	Ductile Iron Pipe Flanges and Flanged Fittings: Classes 150 and 300
B16.44-2012 (R2017)	Manually Operated Metallic Gas Valves for Use in Aboveground Piping Systems Up to 5 psi
B16.47-2020	Large Diameter Steel Flanges: NPS 26 Through NPS 60 Metric/Inch Standard
B16.48-2020	Line Blanks
B16.49-2017	Factory-Made, Wrought Steel, Butt Welding Induction Bends for Transportation and Distribution Systems
B16.50-2018	Wrought Copper and Copper Alloy Braze-Joint Pressure Fittings
B16.51-2018	Copper and Copper Alloy Press-Connect Pressure Fittings
B16.52-2018	Forged Nonferrous Fittings, Socket-Welding and Threaded (Titanium, Titanium Alloys, Aluminum, and Aluminum Alloys)

The ASME Publications Catalog shows a complete list of all the Standards published by the Society. For a complimentary catalog, or the latest information about our publications, call 1-800-THE-ASME (1-800-843-2763).

ASME Services

ASME is committed to developing and delivering technical information. At ASME's Customer Care, we make every effort to answer your questions and expedite your orders. Our representatives are ready to assist you in the following areas:

ASME Press	Member Services & Benefits	Public Information
<i>Codes & Standards</i>	Other ASME Programs	Self-Study Courses
Credit Card Orders	Payment Inquiries	Shipping Information
IMEchE Publications	Professional Development	Subscriptions/Journals/Magazines
Meetings & Conferences	Short Courses	Symposia Volumes
Member Dues Status	Publications	Technical Papers

How can you reach us? It's easier than ever!

There are four options for making inquiries* or placing orders. Simply mail, phone, fax, or E-mail us and a Customer Care representative will handle your request.

<i>Mail</i>	<i>Call Toll Free</i>	<i>Fax—24 hours</i>	<i>E-Mail—24 hours</i>
ASME	US & Canada: 800-THE-ASME	973-882-1717	customer@asme.org
150 Clove Road, 6th Floor	(800-843-2763)	973-882-5155	
Little Falls, New Jersey	Mexico: 95-800-THE-ASME		
07424-2139	(95-800-843-2763)		

*Customer Care staff are not permitted to answer inquiries about the technical content of this code or standard. Information as to whether or not technical inquiries are issued to this code or standard is shown on the copyright page. All technical inquiries must be submitted in writing to the staff secretary. Additional procedures for inquiries may be listed within.

ASME B16.42-2021